

EST. 1994



BUILD YOUR DREAM SPACE



**Weaver Barns** *ltd.*

"everyone needs a little structure in their life"





# SHEDS & BARNES



**Gable** page 20



**Manchester** page 22



**Sugarcreek** page 24



**Craftsman** page 26



**Estate** page 28



**Woodshed** page 30



**Highland** page 32



**Grand Junction** page 34



**Studio** page 36



**Skür** page 38



**Cottage** page 40



**Shed Addition** page 42

# BACKYARD BASICS



**Jackson** page 46



**Addison** page 47



**New Haven** page 48



**Camden** page 49

# BACKYARD LIVING



**Laredo** page 51



**Montecito** page 51



**Timber Ridge** page 52



**Bradford** page 54



**Lakewood** page 56



**Dublin** page 58

# GARAGES



**Gable Garage** page 64



**Workshop** page 66



**Classic** page 68



**Heritage** page 70



**Rockport** page 72



**Willow Creek** page 74



**Cascade** page 76



**Dutch Garage** page 78



**Dutch Barn** page 80

# CABINS



**Frontier** page 82



**Aspen** page 84

# HOMES



**Rocky Ridge** page 87



**Cedar Brooke I** page 88



**Cedar Brooke II** page 89



**Timber Lodge** page 90



**Grand Lake** page 91

*Check out our home brochures for more information!*



# LOOK WHAT YOU CAN DO



- ✓ added windows
- ✓ black metal roof
- ✓ door awnings
- ✓ 10' sidewalls
- ✓ carriage garage doors
- ✓ paint



BASE DESIGN



# SEE HOW THIS CUSTOMER DESIGNED THIS PROJECT



BASE DESIGN

- ✓ added windows
- ✓ black metal roof
- ✓ cupola
- ✓ door awning
- ✓ single door
- ✓ door ramp
- ✓ steeper pitch roof
- ✓ gutters
- ✓ paint





# WELCOME



Since 1994 Weaver Barns has been building two things, structures and a reputation for unmatched quality. We strive to provide the best in everything we do, from customer service to manufacturing and installation. To put it simply, we provide you with an excellent product that you and your family will enjoy for many years to come.



**Weaver Barns** *ltd.*  
"everyone needs a little structure in their life"















# DESIGN STYLES

To find a style that best fits your standards, we have a large variety of features for you to choose from. These styles are all unique and customizable, so you can find one that fits best into your space. Our designs are not only based on appearance but also on their functionality and durability. If you aren't sure what style will work best for your structure, our team is always eager to help guide you by giving recommendations specific to you and what you're looking for.







# OLD WORLD GARDEN FARMS

Weaver Barns gives flexibility, the ability to customize, and most importantly, quality, to each customer we serve. Customers Jim and Mary from *Old World Garden Farms* fell in love with our designs and their ability to customize our structures to work specifically for their needs. Featured on this page are a few of the structures we have built with them. You can find more features on these building projects on their home and garden website. [oldworldgardenfarms.com](http://oldworldgardenfarms.com)









# STRENGTH

A No Compromise Approach to Quality

At Weaver Barns, our culture is quality. Every aspect of the projects we do is done right. We care about building something that will last, and understand that our customers need a space that will stand the test of time. From custom milling our floorboards to buying premium-grade lumber, we use the finest materials we can source. We don't just build a shed, we build the Weaver way.





# FOUNDATION TYPES

## BLOCK SITE PREP

\*not recommended for grades exceeding 8"

Place 8" x 16" x 4" cement blocks underneath the skids. Every skid needs a block at the front and back and then additional blocks need to be placed in the middle spaced not more than 6' apart.

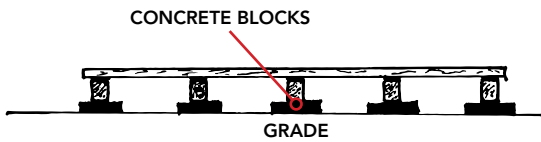

## LIMESTONE PAD

\*the most popular choice for sheds

Spread 4" of #57 limestone in a level pad 12" beyond the width and the length of the building on all sides. You may want to use a 4 x 4 as an edge as shown in the example below.

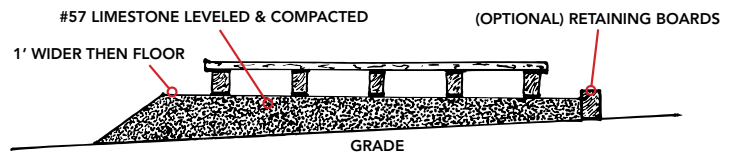

## CONCRETE FOUNDATIONS

Pour the pad 1/2" less than the dimensions of the building. We attach treated plates to the bottom of the walls protecting the walls from moisture and rot. These bottom plates are fastened to the concrete pad with anchors or bolts.

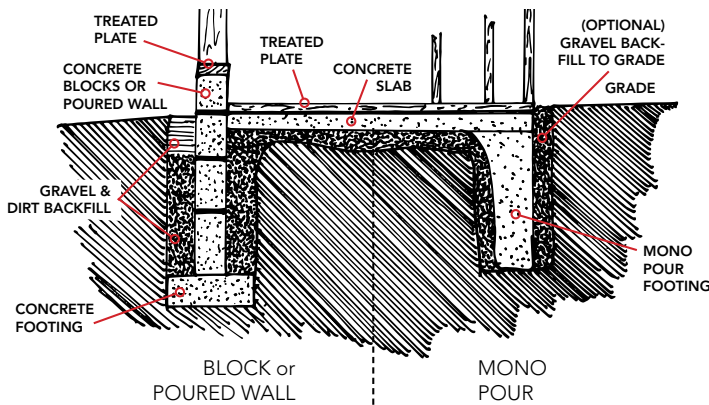

## POST PLATFORM FOUNDATION

Use treated posts. Dig the post holes 32" - 42" deep. Place post pad or concrete in the bottom of the hole. Insert posts. Fasten crossbeam joists with bolts to posts as shown making sure that the entire structure is square.

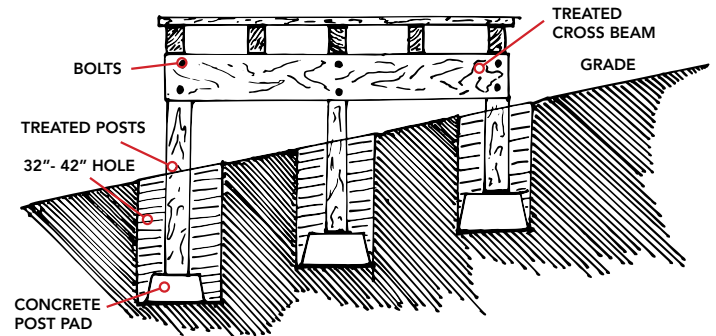

## SHED ON SLAB

To attach a shed to a slab, have your concrete contractor add a 4" reinforced curb. This will keep water from entering the structure.

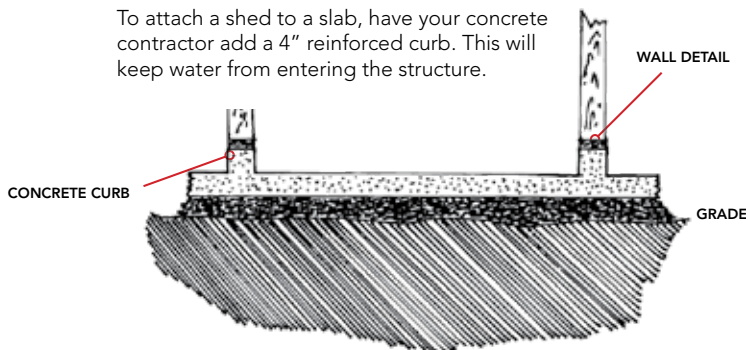

## SKID PLACEMENT

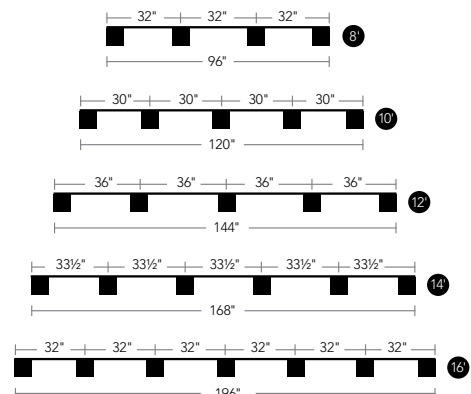



# OUR PRICES INCLUDE DELIVERY

WE DELIVER TO YOUR SITE

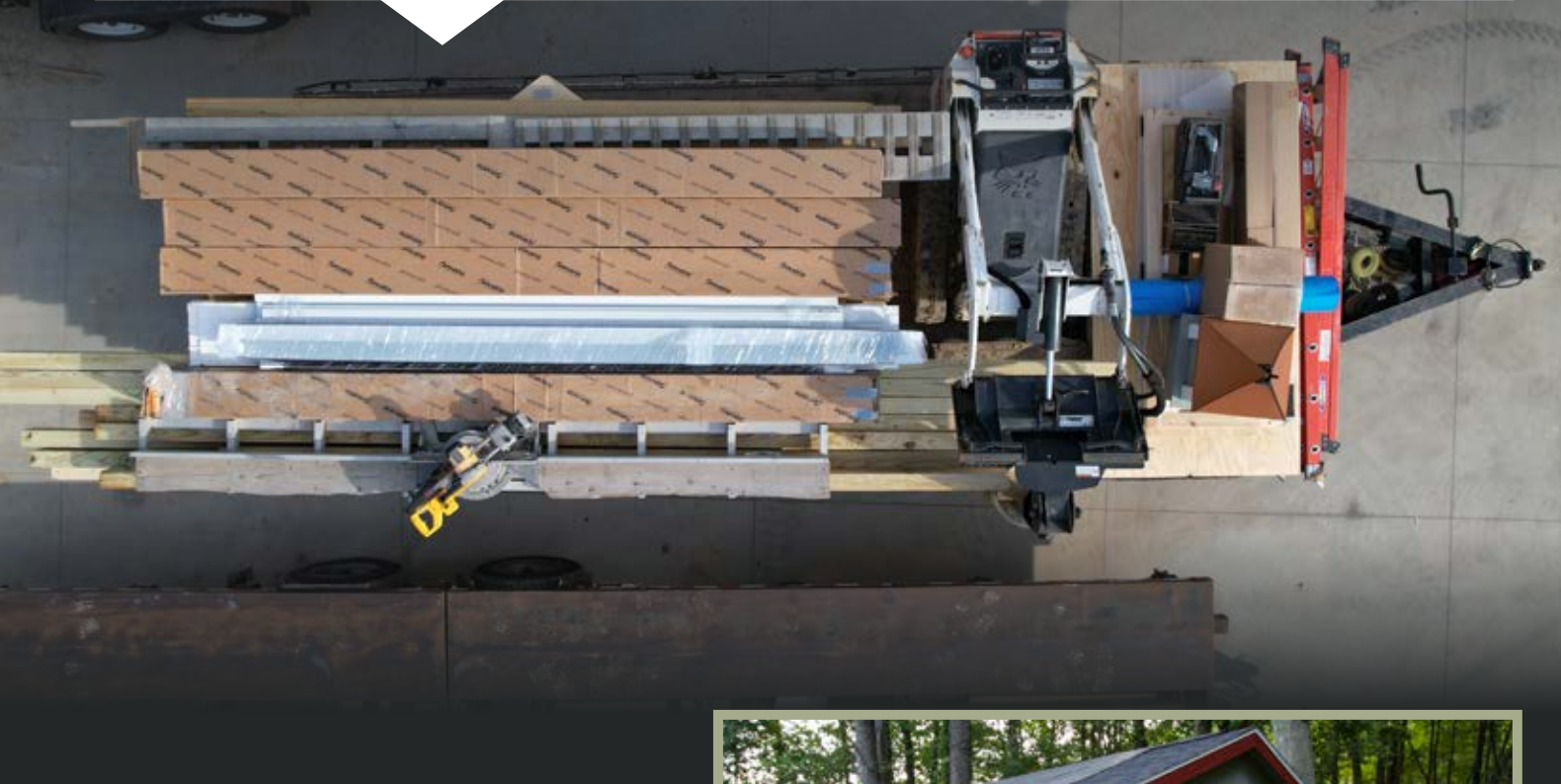

**PREBUILT &  
DELIVERED**

**— OR —**

**DELIVERED &  
BUILT ON SITE**





# DAY OF DELIVERY

**BEYOND FREE DISTANCE APPLIES**  
\$1.00 per foot carry charge

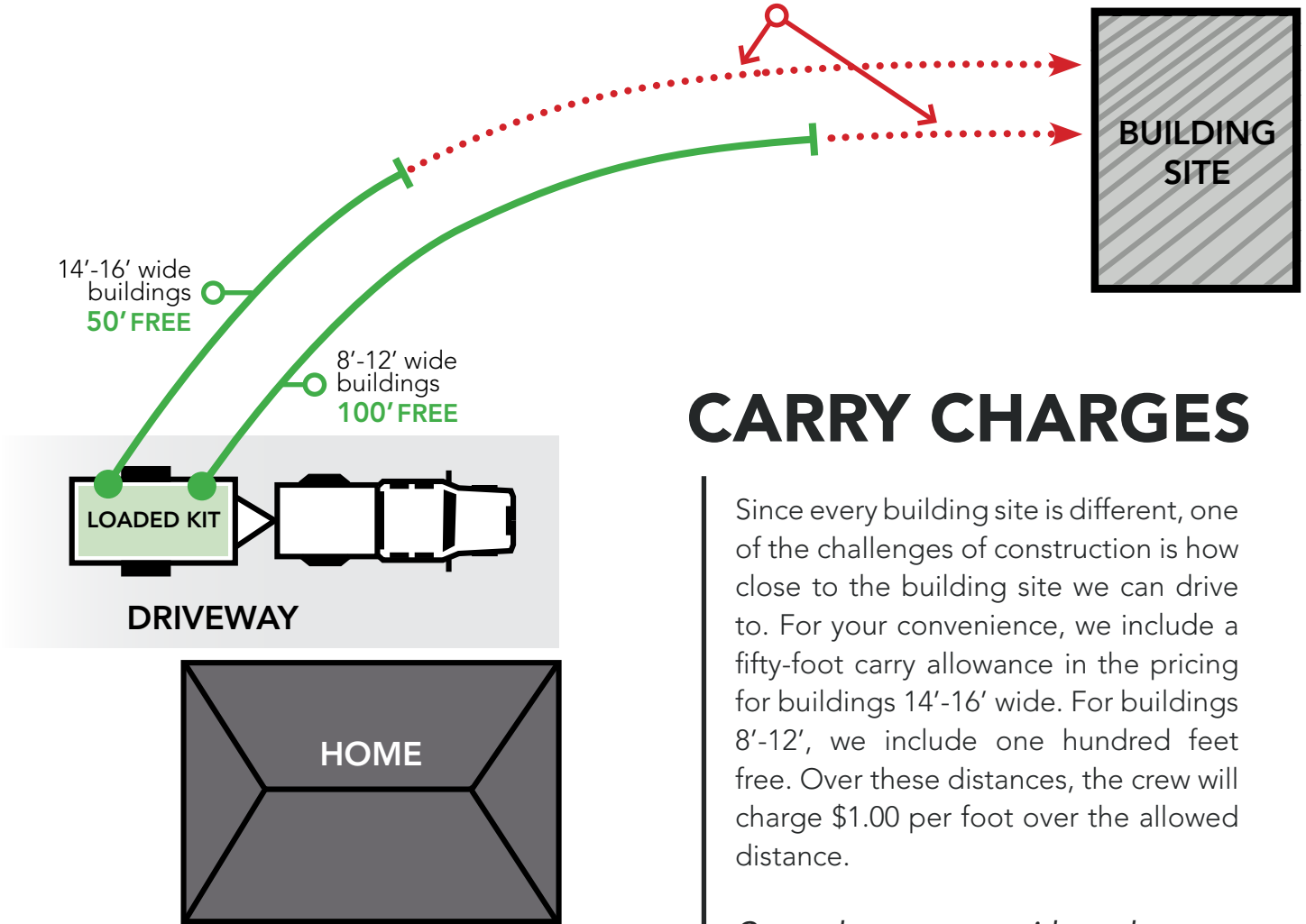

## CARRY CHARGES

Since every building site is different, one of the challenges of construction is how close to the building site we can drive to. For your convenience, we include a fifty-foot carry allowance in the pricing for buildings 14'-16' wide. For buildings 8'-12', we include one hundred feet free. Over these distances, the crew will charge \$1.00 per foot over the allowed distance.

*Carry charges are paid to the crew directly.*





# WHAT SIZE IS RIGHT?

When determining what size is right for your structure, we encourage you to talk to one of our qualified team members to figure out what works best for you. There are a lot of decisions that go into creating a structure, and we want to make that process as easy as possible for you, whether it's a custom garage or even a shed.

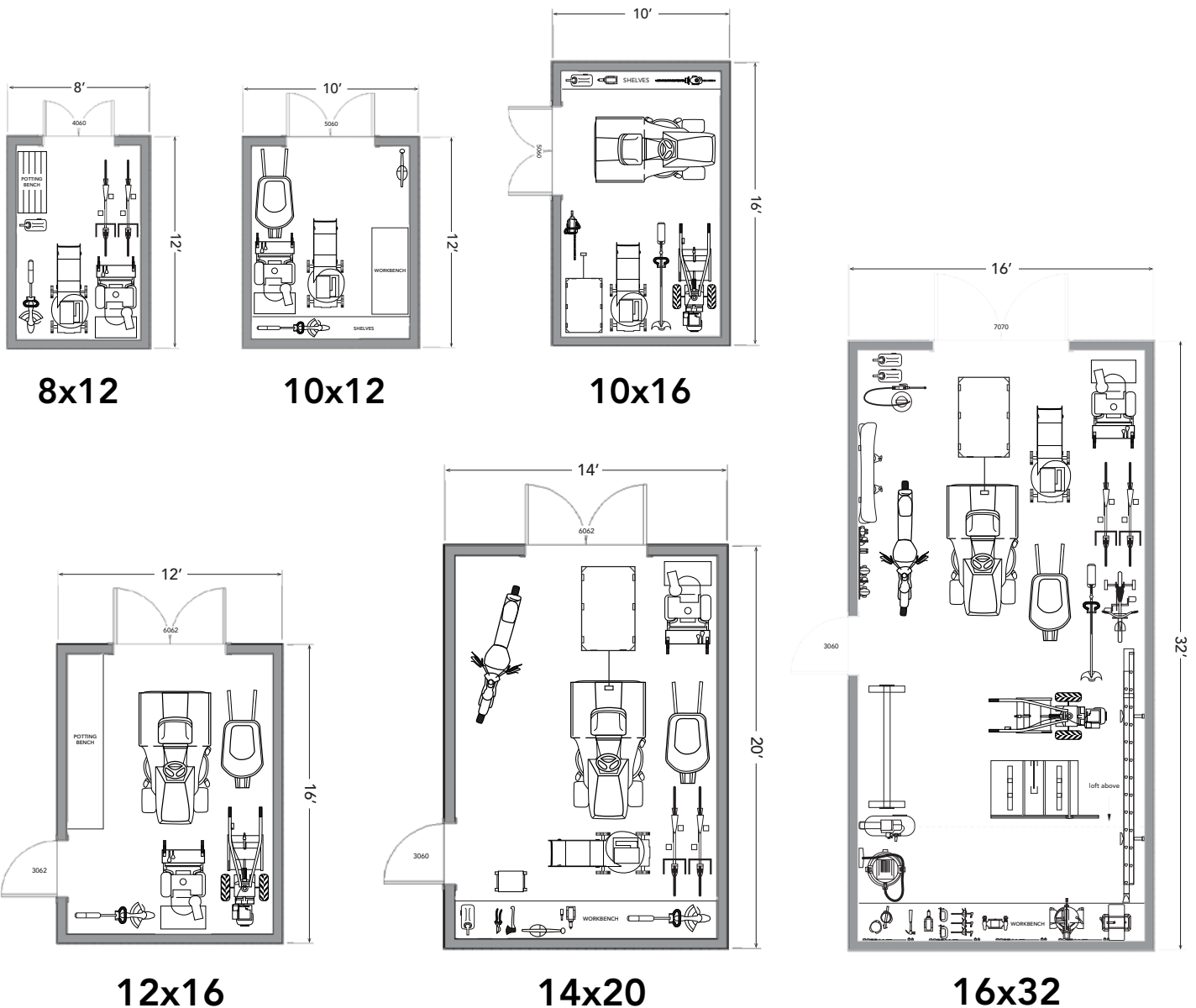









# SIGNATURE FEATURES



## COOLER

ENGINEERED VENTILATION SYSTEM  
extends shed lifespan

## ROOFING FELT

EXTRA MOISTURE PROTECTION  
extends shed lifespan

## STRONGER ROOF

ROOF SHEATHING  
superior plywood strength

## WEATHER PROTECTED

ROT RESISTANT TRIM  
protects from moisture damage

## MORE STORAGE

7' 3 1/2" HIGH  
higher walls

## STURDY DOORS

TRIPLE LAYER DOOR (WITH DROP RODS)  
solid cedar

## SUPERIOR FRAMING

PREMIUM GRADE  
better lumber

2X6 DOUBLE DOOR HEADERS  
2X4 DOUBLE STUD DOOR FRAMES  
stronger door frames

16 INCHES ON CENTER  
stronger studs & rafters

## TOUGHER FLOOR

RATED 1,000 LB. PER SQ. FT. (PRESSURE TREATED)  
heaviest floor in the industry

STANDARD ON SIGNATURE SERIES



# SIDING CHOICES

## LP LAP SIDING

- 50-YEAR LIMITED WARRANTY
- Natural Woodgrain Texture
- 100% Clear
- Pre-Primed
- 50-Year Limited Warranty



## VINYL SIDING

- Maintenance Free
- .044 Thickness
- Match Your Home
- CDX Plywood Subsidng



## PINE SIDING

- 1 x 8 Premium-Grade Pine Siding
- Exclusive Rough-Sawn Finish
- Aesthetically Pleasing
- Tongue & Groove



## BOARD & BATTEN

- 50 YEAR LIMITED WARRANTY
- Natural Woodgrain Texture
- 100% Clear
- Pre-Primed
- 50-Year Limited Warranty



## DURATEMP SIDING

- 50-YEAR LIMITED WARRANTY
- Natural Woodgrain Texture
- 100% Clear
- Pre-Primed
- 50-Year Limited Warranty



## SMARTSIDE SIDING

- 50-YEAR LIMITED WARRANTY
- Natural Woodgrain Texture
- 100% Clear
- Pre-Primed
- 50-Year Limited Warranty







# Gable

Storage • Workshop • Gardening

## OPTIONS

*ON THIS 10x16*

- Estate Gray Dimensional Shingles
- 2'x3' Windows
- 202TW Doors
- Dark Gray / White





## BASE PRICE UNIT HOW IT'S BUILT



## CONFIGURATION IDEAS



## SIDING CHOICES view pricing guide for current pricing

<p><b>SMARTSIDE LAP SIDING</b></p> <p>50-YEAR LIMITED WARRANTY</p> <ul style="list-style-type: none"> <li>Natural Woodgrain Texture</li> <li>100% Clear</li> <li>Pre-Primed</li> <li>50-Year Limited Warranty</li> </ul>	<p><b>VINYL SIDING</b></p> <ul style="list-style-type: none"> <li>Maintenance Free</li> <li>D44 Thickness</li> <li>Match Your Home</li> <li>CDX Plywood Subsiding</li> </ul>	<p><b>PINE SIDING</b></p> <ul style="list-style-type: none"> <li>1 x 8 Premium-Grade Pine Siding</li> <li>Exclusive Rough-Sawn Finish</li> <li>Aesthetically Pleasing</li> <li>Tongue &amp; Groove</li> </ul>	<p><b>BOARD &amp; BATTEN</b></p> <p>50-YEAR LIMITED WARRANTY</p> <ul style="list-style-type: none"> <li>Natural Woodgrain Texture</li> <li>100% Clear</li> <li>Pre-Primed</li> <li>50-Year Limited Warranty</li> </ul>	<p><b>DURATEMP SIDING</b></p> <p>50-YEAR LIMITED WARRANTY</p> <ul style="list-style-type: none"> <li>Natural Woodgrain Texture</li> <li>100% Clear</li> <li>Pre-Primed</li> <li>50-Year Limited Warranty</li> </ul>	<p><b>SMARTSIDE SIDING</b></p> <p>50-YEAR LIMITED WARRANTY</p> <ul style="list-style-type: none"> <li>Natural Woodgrain Texture</li> <li>100% Clear</li> <li>Pre-Primed</li> <li>50-Year Limited Warranty</li> </ul>
--	--	---	--	---	--





# Manchester

Storage • Horse Barn • Gardening

## OPTIONS

*ON THIS 10x14*

Teak Dimensional Shingles  
5' Sidewall Height  
202TW Doors  
Peak Extension & Bracket  
Bear Beige / Bronze / Pecan





## BASE PRICE UNIT

HOW IT'S BUILT



## CONFIGURATION IDEAS



## SIDING CHOICES view pricing guide for current pricing

<p><b>SMARTSIDE LAP SIDING</b>                  50-YEAR LIMITED WARRANTY                  • Natural Woodgrain Texture                  • 100% Clear                  • Pre-Primed                  • 50-Year Limited Warranty</p> 	<p><b>VINYL SIDING</b>                  • Maintenance Free                  • D44 Thickness                  • Match Your Home                  • CDX Plywood Subsiding</p> 	<p><b>PINE SIDING</b>                  • 1 x 8 Premium-Grade Pine Siding                  • Exclusive Rough-Sawn Finish                  • Aesthetically Pleasing                  • Tongue &amp; Groove</p> 	<p><b>BOARD &amp; BATTEN</b>                  50-YEAR LIMITED WARRANTY                  • Natural Woodgrain Texture                  • 100% Clear                  • Pre-Primed                  • 50-Year Limited Warranty</p> 	<p><b>DURATEMP SIDING</b>                  50-YEAR LIMITED WARRANTY                  • Natural Woodgrain Texture                  • 100% Clear                  • Pre-Primed                  • 50-Year Limited Warranty</p> 	<p><b>SMARTSIDE SIDING</b>                  50-YEAR LIMITED WARRANTY                  • Natural Woodgrain Texture                  • 100% Clear                  • Pre-Primed                  • 50-Year Limited Warranty</p> 
---	---	--	---	--	---





# Sugarcreek

Storage • Poolhouse • Gardening

## OPTIONS

*ON THIS 10x16*

Driftwood Dimensional Shingles

2'x3' Windows + Transoms

102TW Doors

Navajo White Traditional Cupola

Buckskin / Navajo White / Bronze





## BASE PRICE UNIT HOW IT'S BUILT



## CONFIGURATION IDEAS



## SIDING CHOICES view pricing guide for current pricing

<p><b>SMARTSIDE LAP SIDING</b></p> <p>50-YEAR LIMITED WARRANTY</p> <ul style="list-style-type: none"> <li>Natural Woodgrain Texture</li> <li>100% Clear</li> <li>Pre-Primed</li> <li>50-Year Limited Warranty</li> </ul>	<p><b>VINYL SIDING</b></p> <ul style="list-style-type: none"> <li>Maintenance Free</li> <li>D44 Thickness</li> <li>Match Your Home</li> <li>CDX Plywood Subsidizing</li> </ul>	<p><b>PINE SIDING</b></p> <ul style="list-style-type: none"> <li>1 x 8 Premium-Grade Pine Siding</li> <li>Exclusive Rough-Sawn Finish</li> <li>Aesthetically Pleasing</li> <li>Tongue &amp; Groove</li> </ul>	<p><b>BOARD &amp; BATTEN</b></p> <p>50-YEAR LIMITED WARRANTY</p> <ul style="list-style-type: none"> <li>Natural Woodgrain Texture</li> <li>100% Clear</li> <li>Pre-Primed</li> <li>50-Year Limited Warranty</li> </ul>	<p><b>DURATEMP SIDING</b></p> <p>50 YEAR LIMITED WARRANTY</p> <ul style="list-style-type: none"> <li>Natural Woodgrain Texture</li> <li>100% Clear</li> <li>Pre-Primed</li> <li>50-Year Limited Warranty</li> </ul>	<p><b>SMARTSIDE SIDING</b></p> <p>50-YEAR LIMITED WARRANTY</p> <ul style="list-style-type: none"> <li>Natural Woodgrain Texture</li> <li>100% Clear</li> <li>Pre-Primed</li> <li>50-Year Limited Warranty</li> </ul>
--	--	---	--	---	--





# Craftsman

Workshop • Potting Shed • Poolhouse

## OPTIONS

*ON THIS 10x14*

Driftwood Dimensional Shingles  
2'x3' Windows  
202TW Doors  
Flower Box / Shutter Set  
Avocado / Almond / Bark





## BASE PRICE UNIT

### HOW IT'S BUILT



### CONFIGURATION IDEAS



## SIDING CHOICES view pricing guide for current pricing

<p><b>SMARTSIDE LAP SIDING</b></p> <p>50-YEAR LIMITED WARRANTY</p> <ul style="list-style-type: none"> <li>Natural Woodgrain Texture</li> <li>100% Clear</li> <li>Pre-Primed</li> <li>50-Year Limited Warranty</li> </ul>	<p><b>VINYL SIDING</b></p> <ul style="list-style-type: none"> <li>Maintenance Free</li> <li>D44 Thickness</li> <li>Match Your Home</li> <li>CDX Plywood Subsidizing</li> </ul>	<p><b>PINE SIDING</b></p> <ul style="list-style-type: none"> <li>1 x 8 Premium-Grade Pine Siding</li> <li>Exclusive Rough-Sawn Finish</li> <li>Aesthetically Pleasing</li> <li>Tongue &amp; Groove</li> </ul>	<p><b>BOARD &amp; BATTEN</b></p> <p>50-YEAR LIMITED WARRANTY</p> <ul style="list-style-type: none"> <li>Natural Woodgrain Texture</li> <li>100% Clear</li> <li>Pre-Primed</li> <li>50-Year Limited Warranty</li> </ul>	<p><b>DURATEMP SIDING</b></p> <p>50 YEAR LIMITED WARRANTY</p> <ul style="list-style-type: none"> <li>Natural Woodgrain Texture</li> <li>100% Clear</li> <li>Pre-Primed</li> <li>50-Year Limited Warranty</li> </ul>	<p><b>SMARTSIDE SIDING</b></p> <p>50-YEAR LIMITED WARRANTY</p> <ul style="list-style-type: none"> <li>Natural Woodgrain Texture</li> <li>100% Clear</li> <li>Pre-Primed</li> <li>50-Year Limited Warranty</li> </ul>
--	--	---	--	---	--





# Estate

Storage • Workshop • Studio

## OPTIONS

*ON THIS 12x16*

Driftwood Dimensional Shingles  
2'x3' Windows  
101SW + Vertical Trim Board Doors  
Flower Box / Shutter Set  
Shale / Navajo White / Natural





## BASE PRICE UNIT

### HOW IT'S BUILT



### CONFIGURATION IDEAS



## SIDING CHOICES view pricing guide for current pricing

<p><b>SMARTSIDE LAP SIDING</b>                  50-YEAR LIMITED WARRANTY                  • Natural Woodgrain Texture                  • 100% Clear                  • Pre-Primed                  • 50-Year Limited Warranty</p>	<p><b>VINYL SIDING</b>                  • Maintenance Free                  • D44 Thickness                  • Match Your Home                  • CDX Plywood Subsidng</p>	<p><b>PINE SIDING</b>                  • 1 x 8 Premium-Grade Pine Siding                  • Exclusive Rough-Sawn Finish                  • Aesthetically Pleasing                  • Tongue &amp; Groove</p>	<p><b>BOARD &amp; BATTEN</b>                  50-YEAR LIMITED WARRANTY                  • Natural Woodgrain Texture                  • 100% Clear                  • Pre-Primed                  • 50-Year Limited Warranty</p>	<p><b>DURATEMP SIDING</b>                  50-YEAR LIMITED WARRANTY                  • Natural Woodgrain Texture                  • 100% Clear                  • Pre-Primed                  • 50-Year Limited Warranty</p>	<p><b>SMARTSIDE SIDING</b>                  50-YEAR LIMITED WARRANTY                  • Natural Woodgrain Texture                  • 100% Clear                  • Pre-Primed                  • 50-Year Limited Warranty</p>
---	--	--	---	--	---





# Woodshed

Workshop • Cabin • Poolhouse

## OPTIONS

*ON THIS 10x16*

Galvalume Metal Roof

2'x3' Windows

Shutter Set

204 SD Front Door

Cupola

Ebony / Black / Chestnut Brown





## BASE PRICE UNIT HOW IT'S BUILT



## CONFIGURATION IDEAS



## SIDING CHOICES view pricing guide for current pricing

<p><b>SMARTSIDE LAP SIDING</b></p> <p>50-YEAR LIMITED WARRANTY</p> <ul style="list-style-type: none"> <li>Natural Woodgrain Texture</li> <li>100% Clear</li> <li>Pre-Primed</li> <li>50-Year Limited Warranty</li> </ul>	<p><b>VINYL SIDING</b></p> <ul style="list-style-type: none"> <li>Maintenance Free</li> <li>D44 Thickness</li> <li>Match Your Home</li> <li>CDX Plywood Subsidizing</li> </ul>	<p><b>PINE SIDING</b></p> <ul style="list-style-type: none"> <li>1 x 8 Premium-Grade Pine Siding</li> <li>Exclusive Rough-Sawn Finish</li> <li>Aesthetically Pleasing</li> <li>Tongue &amp; Groove</li> </ul>	<p><b>BOARD &amp; BATTEN</b></p> <p>50-YEAR LIMITED WARRANTY</p> <ul style="list-style-type: none"> <li>Natural Woodgrain Texture</li> <li>100% Clear</li> <li>Pre-Primed</li> <li>50-Year Limited Warranty</li> </ul>	<p><b>DURATEMP SIDING</b></p> <p>50-YEAR LIMITED WARRANTY</p> <ul style="list-style-type: none"> <li>Natural Woodgrain Texture</li> <li>100% Clear</li> <li>Pre-Primed</li> <li>50-Year Limited Warranty</li> </ul>	<p><b>SMARTSIDE SIDING</b></p> <p>50-YEAR LIMITED WARRANTY</p> <ul style="list-style-type: none"> <li>Natural Woodgrain Texture</li> <li>100% Clear</li> <li>Pre-Primed</li> <li>50-Year Limited Warranty</li> </ul>
--	--	---	--	---	--





# Highland

Potting Shed • Cabin • Poolhouse

## OPTIONS

*ON THIS 10x16*

Onyx Black Dimensional Shingles

2'x4' Windows

203LW Doors

Pioneer Brown / Natural





## BASE PRICE UNIT

### HOW IT'S BUILT



### CONFIGURATION IDEAS



## SIDING CHOICES view pricing guide for current pricing

<p><b>SMARTSIDE LAP SIDING</b></p> <p>50-YEAR LIMITED WARRANTY</p> <ul style="list-style-type: none"> <li>Natural Woodgrain Texture</li> <li>100% Clear</li> <li>Pre-Primed</li> <li>50-Year Limited Warranty</li> </ul>	<p><b>VINYL SIDING</b></p> <ul style="list-style-type: none"> <li>Maintenance Free</li> <li>D44 Thickness</li> <li>Match Your Home</li> <li>CDX Plywood Subsiding</li> </ul>	<p><b>PINE SIDING</b></p> <ul style="list-style-type: none"> <li>1 x 8 Premium-Grade Pine Siding</li> <li>Exclusive Rough-Sawn Finish</li> <li>Aesthetically Pleasing</li> <li>Tongue &amp; Groove</li> </ul>	<p><b>BOARD &amp; BATTEN</b></p> <p>50-YEAR LIMITED WARRANTY</p> <ul style="list-style-type: none"> <li>Natural Woodgrain Texture</li> <li>100% Clear</li> <li>Pre-Primed</li> <li>50-Year Limited Warranty</li> </ul>	<p><b>DURATEMP SIDING</b></p> <p>50-YEAR LIMITED WARRANTY</p> <ul style="list-style-type: none"> <li>Natural Woodgrain Texture</li> <li>100% Clear</li> <li>Pre-Primed</li> <li>50-Year Limited Warranty</li> </ul>	<p><b>SMARTSIDE SIDING</b></p> <p>50-YEAR LIMITED WARRANTY</p> <ul style="list-style-type: none"> <li>Natural Woodgrain Texture</li> <li>100% Clear</li> <li>Pre-Primed</li> <li>50-Year Limited Warranty</li> </ul>
--	--	---	--	---	--





# Grand Junction

Storage • Gardening • Studio

## OPTIONS

*ON THIS 10x16*

Estate Gray Dimensional Shingles

2'x3' Windows

103AW Cedar Double Door

Z Strap Shutters

Square-Cut Trim

Chestnut Brown / Jamestown Red / Bronze





## BASE PRICE UNIT

HOW IT'S BUILT



## CONFIGURATION IDEAS



## SIDING CHOICES view pricing guide for current pricing

<p><b>SMARTSIDE LAP SIDING</b></p> <p>50-YEAR LIMITED WARRANTY</p> <ul style="list-style-type: none"> <li>Natural Woodgrain Texture</li> <li>100% Clear</li> <li>Pre-Primed</li> <li>50-Year Limited Warranty</li> </ul>	<p><b>VINYL SIDING</b></p> <ul style="list-style-type: none"> <li>Maintenance Free</li> <li>D44 Thickness</li> <li>Match Your Home</li> <li>CDX Plywood Subsidizing</li> </ul>	<p><b>PINE SIDING</b></p> <ul style="list-style-type: none"> <li>1 x 8 Premium-Grade Pine Siding</li> <li>Exclusive Rough-Sawn Finish</li> <li>Aesthetically Pleasing</li> <li>Tongue &amp; Groove</li> </ul>	<p><b>BOARD &amp; BATTEN</b></p> <p>50-YEAR LIMITED WARRANTY</p> <ul style="list-style-type: none"> <li>Natural Woodgrain Texture</li> <li>100% Clear</li> <li>Pre-Primed</li> <li>50-Year Limited Warranty</li> </ul>	<p><b>DURATEMP SIDING</b></p> <p>50-YEAR LIMITED WARRANTY</p> <ul style="list-style-type: none"> <li>Natural Woodgrain Texture</li> <li>100% Clear</li> <li>Pre-Primed</li> <li>50-Year Limited Warranty</li> </ul>	<p><b>SMARTSIDE SIDING</b></p> <p>50-YEAR LIMITED WARRANTY</p> <ul style="list-style-type: none"> <li>Natural Woodgrain Texture</li> <li>100% Clear</li> <li>Pre-Primed</li> <li>50-Year Limited Warranty</li> </ul>
--	--	---	--	---	--





# Studio

Studio • Poolhouse • Gardening

## OPTIONS

*ON THIS 10x18*

2'x2' Windows

2'x3' Windows

Square-Cut Trim

202TW Doors

Chestnut Brown / Buckskin / Jamestown Red





## BASE PRICE UNIT

### HOW IT'S BUILT

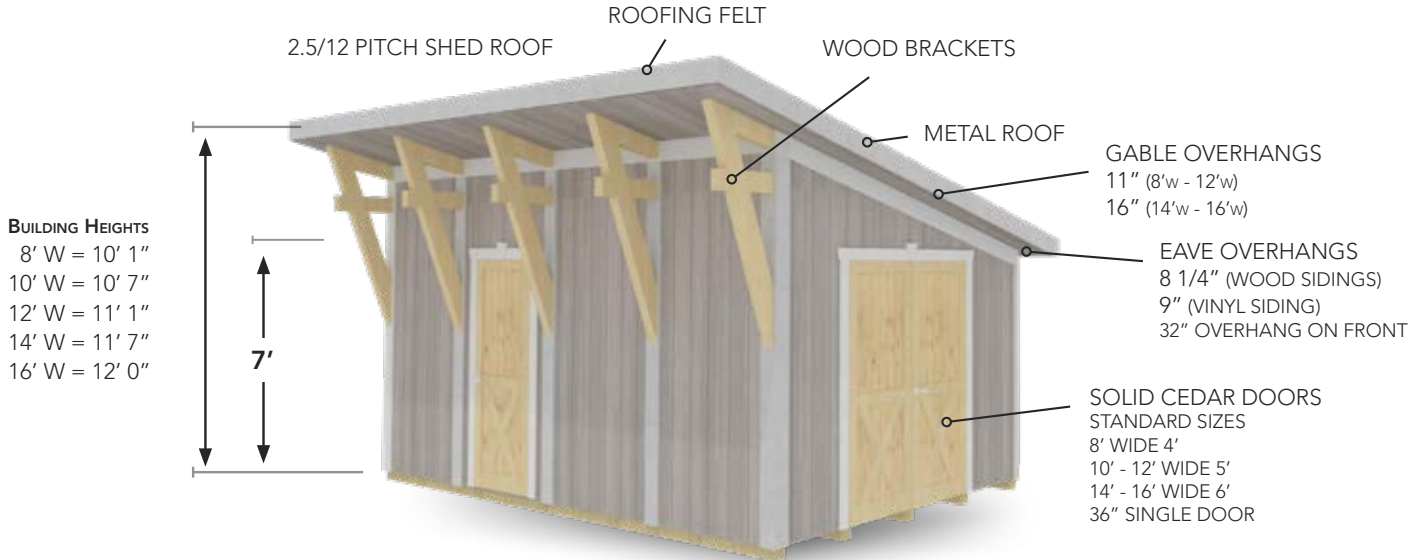

### CONFIGURATION IDEAS



## SIDING CHOICES view pricing guide for current pricing

<p><b>SMARTSIDE LAP SIDING</b>                  50-YEAR LIMITED WARRANTY                  • Natural Woodgrain Texture                  • 100% Clear                  • Pre-Primed                  • 50-Year Limited Warranty</p> 	<p><b>VINYL SIDING</b>                  • Maintenance Free                  • D44 Thickness                  • Match Your Home                  • CDX Plywood Subsidizing</p> 	<p><b>PINE SIDING</b>                  • 1 x 8 Premium-Grade Pine Siding                  • Exclusive Rough-Sawn Finish                  • Aesthetically Pleasing                  • Tongue &amp; Groove</p> 	<p><b>BOARD &amp; BATTEN</b>                  50-YEAR LIMITED WARRANTY                  • Natural Woodgrain Texture                  • 100% Clear                  • Pre-Primed                  • 50-Year Limited Warranty</p> 	<p><b>DURATEMP SIDING</b>                  50-YEAR LIMITED WARRANTY                  • Natural Woodgrain Texture                  • 100% Clear                  • Pre-Primed                  • 50-Year Limited Warranty</p> 	<p><b>SMARTSIDE SIDING</b>                  50-YEAR LIMITED WARRANTY                  • Natural Woodgrain Texture                  • 100% Clear                  • Pre-Primed                  • 50-Year Limited Warranty</p> 
---	---	--	---	--	---





# Skür

Storage • Studio • Poolhouse

## OPTIONS

*ON THIS 10x14*

Onyx Black Dimensional Shingles  
2'x5' Windows  
Square-Cut Trim  
204-SD Single Door (no grids)  
Black / Natural





## BASE PRICE UNIT HOW IT'S BUILT

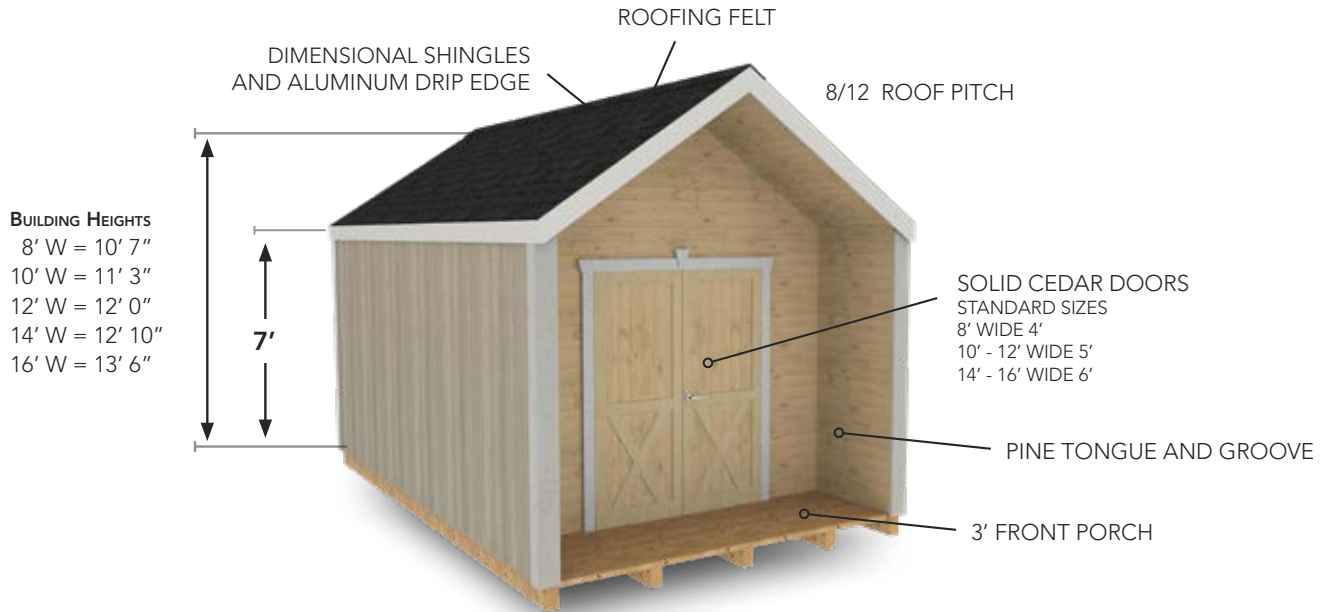

## CONFIGURATION IDEAS



## SIDING CHOICES view pricing guide for current pricing

<p><b>SMARTSIDE LAP SIDING</b></p> <p>50-YEAR LIMITED WARRANTY</p> <ul style="list-style-type: none"> <li>Natural Woodgrain Texture</li> <li>100% Clear</li> <li>Pre-Primed</li> <li>50-Year Limited Warranty</li> </ul>	<p><b>VINYL SIDING</b></p> <ul style="list-style-type: none"> <li>Maintenance Free</li> <li>D44 Thickness</li> <li>Match Your Home</li> <li>CDX Plywood Subsidizing</li> </ul>	<p><b>PINE SIDING</b></p> <ul style="list-style-type: none"> <li>1 x 8 Premium-Grade Pine Siding</li> <li>Exclusive Rough-Sawn Finish</li> <li>Aesthetically Pleasing</li> <li>Tongue &amp; Groove</li> </ul>	<p><b>BOARD &amp; BATTEN</b></p> <p>50-YEAR LIMITED WARRANTY</p> <ul style="list-style-type: none"> <li>Natural Woodgrain Texture</li> <li>100% Clear</li> <li>Pre-Primed</li> <li>50-Year Limited Warranty</li> </ul>	<p><b>DURATEMP SIDING</b></p> <p>50-YEAR LIMITED WARRANTY</p> <ul style="list-style-type: none"> <li>Natural Woodgrain Texture</li> <li>100% Clear</li> <li>Pre-Primed</li> <li>50-Year Limited Warranty</li> </ul>	<p><b>SMARTSIDE SIDING</b></p> <p>50-YEAR LIMITED WARRANTY</p> <ul style="list-style-type: none"> <li>Natural Woodgrain Texture</li> <li>100% Clear</li> <li>Pre-Primed</li> <li>50-Year Limited Warranty</li> </ul>
--	--	---	--	---	--





# Cottage

Studio • Office • Storage

## OPTIONS

*ON THIS 10x16*

Legacy Panel Black Metal Roofing  
16" x 16" Transom Windows  
2' x 3' Windows  
Square-Cut Trim  
White





## BASE PRICE UNIT

### HOW IT'S BUILT

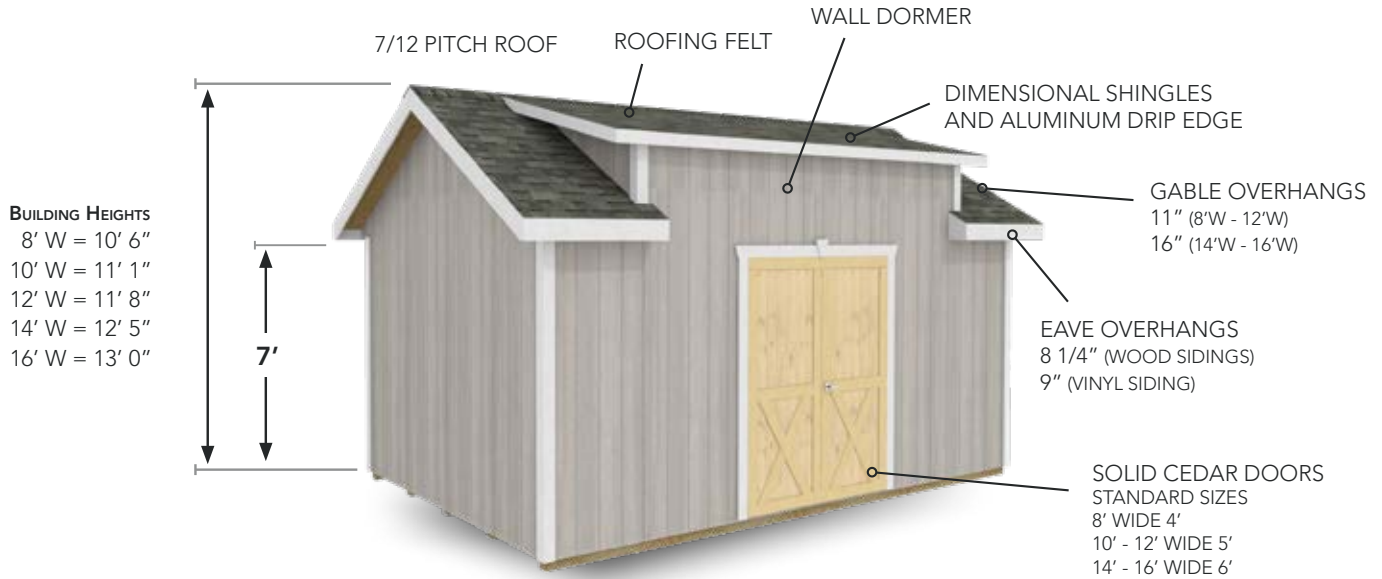

### CONFIGURATION IDEAS



## SIDING CHOICES view pricing guide for current pricing

<p><b>SMARTSIDE LAP SIDING</b>                  50-YEAR LIMITED WARRANTY                  • Natural Woodgrain Texture                  • 100% Clear                  • Pre-Primed                  • 50-Year Limited Warranty</p>	<p><b>VINYL SIDING</b>                  • Maintenance Free                  • D44 Thickness                  • Match Your Home                  • CDX Plywood Subsidizing</p>	<p><b>PINE SIDING</b>                  • 1 x 8 Premium-Grade Pine Siding                  • Exclusive Rough-Sawn Finish                  • Aesthetically Pleasing                  • Tongue &amp; Groove</p>	<p><b>BOARD &amp; BATTEN</b>                  50-YEAR LIMITED WARRANTY                  • Natural Woodgrain Texture                  • 100% Clear                  • Pre-Primed                  • 50-Year Limited Warranty</p>	<p><b>DURATEMP SIDING</b>                  50 YEAR LIMITED WARRANTY                  • Natural Woodgrain Texture                  • 100% Clear                  • Pre-Primed                  • 50-Year Limited Warranty</p>	<p><b>SMARTSIDE SIDING</b>                  50-YEAR LIMITED WARRANTY                  • Natural Woodgrain Texture                  • 100% Clear                  • Pre-Primed                  • 50-Year Limited Warranty</p>
---	---	--	---	--	---





# Shed Addition

Storage • Gardening

## OPTIONS

*ON THIS 4x8*

Pictured: 12x18 Gable  
Jamestown Red





## BASE PRICE UNIT

### HOW IT'S BUILT

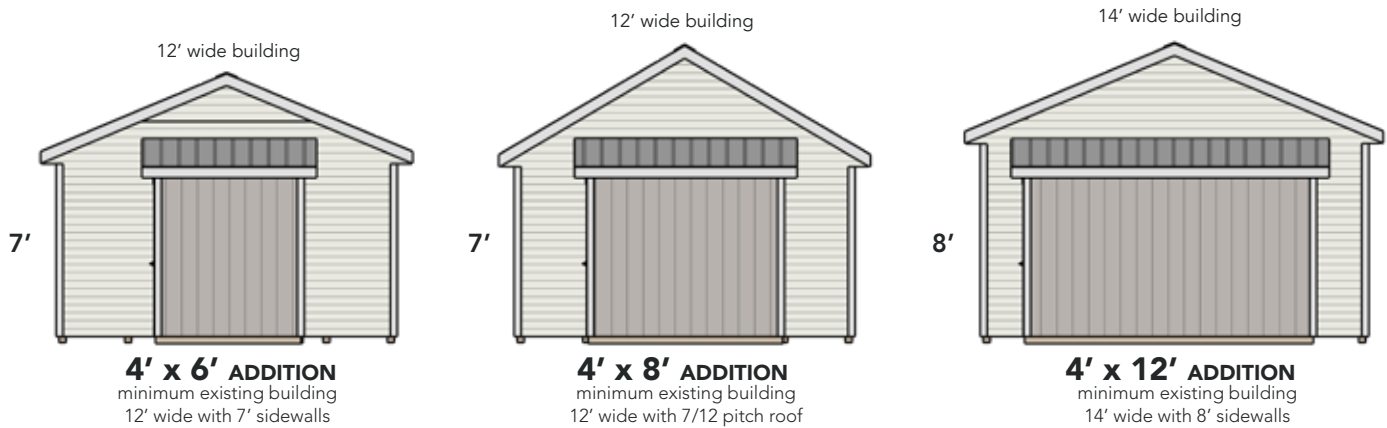

## SIDING CHOICES view pricing guide for current pricing

<p><b>SMARTSIDE LAP SIDING</b></p> <p>50-YEAR LIMITED WARRANTY</p> <ul style="list-style-type: none"> <li>Natural Woodgrain Texture</li> <li>100% Clear</li> <li>Pre-Primed</li> <li>50-Year Limited Warranty</li> </ul>	<p><b>VINYL SIDING</b></p> <ul style="list-style-type: none"> <li>Maintenance Free</li> <li>D44 Thickness</li> <li>Match Your Home</li> <li>CDX Plywood Subsidizing</li> </ul>	<p><b>PINE SIDING</b></p> <ul style="list-style-type: none"> <li>1 x 8 Premium-Grade Pine Siding</li> <li>Exclusive Rough-Sawn Finish</li> <li>Aesthetically Pleasing</li> <li>Tongue &amp; Groove</li> </ul>	<p><b>BOARD &amp; BATTEN</b></p> <p>50-YEAR LIMITED WARRANTY</p> <ul style="list-style-type: none"> <li>Natural Woodgrain Texture</li> <li>100% Clear</li> <li>Pre-Primed</li> <li>50-Year Limited Warranty</li> </ul>	<p><b>DURATEMP SIDING</b></p> <p>50 YEAR LIMITED WARRANTY</p> <ul style="list-style-type: none"> <li>Natural Woodgrain Texture</li> <li>100% Clear</li> <li>Pre-Primed</li> <li>50-Year Limited Warranty</li> </ul>	<p><b>SMARTSIDE SIDING</b></p> <p>50-YEAR LIMITED WARRANTY</p> <ul style="list-style-type: none"> <li>Natural Woodgrain Texture</li> <li>100% Clear</li> <li>Pre-Primed</li> <li>50-Year Limited Warranty</li> </ul>
--	--	---	--	---	--



# TBASICS

STANDARD ON BACKYARD BASICS SHEDS

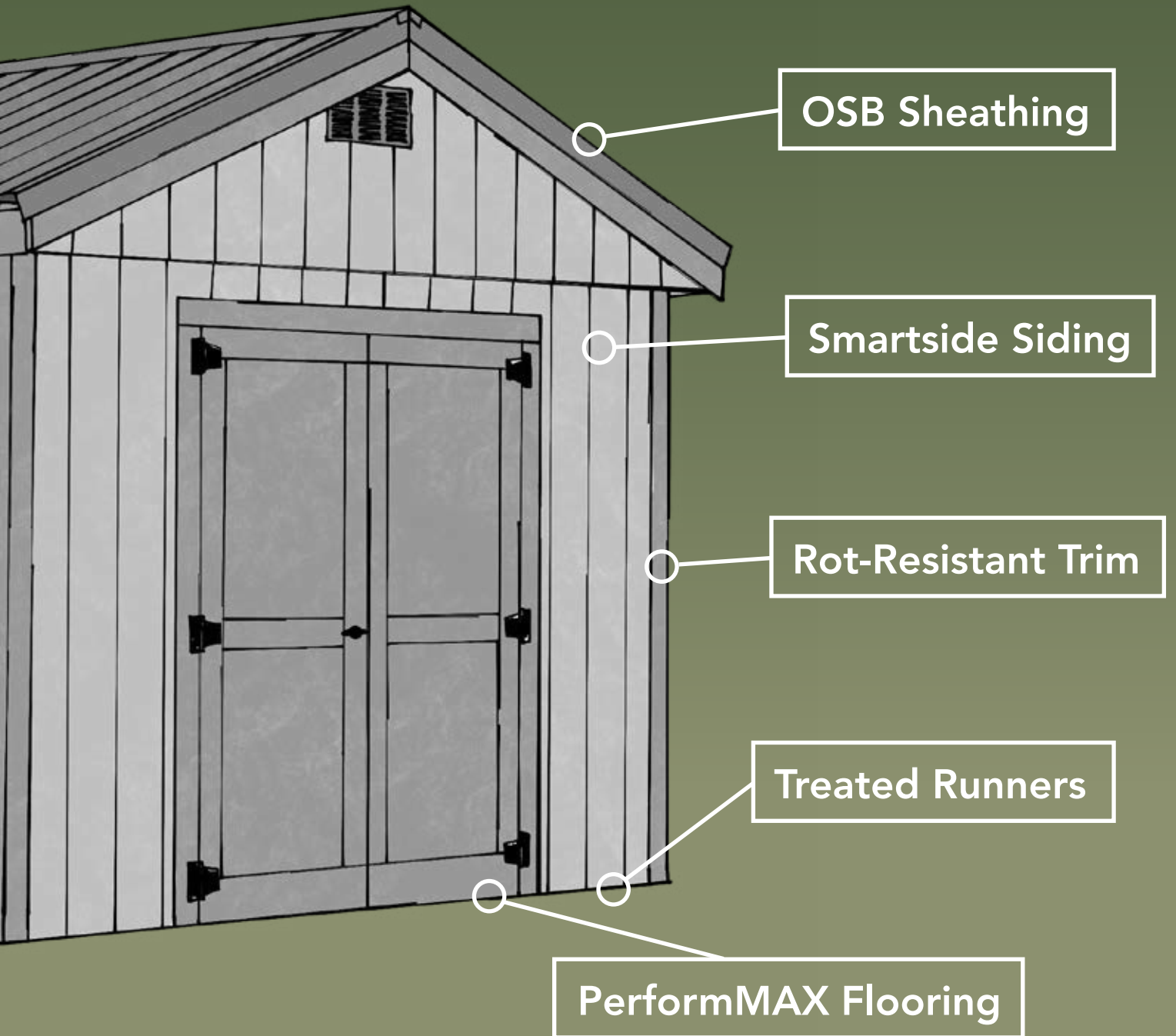



# BACKYARD BASICS

**Simple** is sometimes better. At Weaver Barns, we decided to take this principle and turn it into our BACKYARD BASICS. Using our core models, we created this new line that focuses on simplicity.

## 2-YEAR LIMITED WARRANTY

The first model, the JACKSON, features a classic gable-style roof. We created this design with a focus on functionality and simplicity. This model is a fantastic option for those in search of a storage space or workshop.

Our mono-slope model, the ADDISON, stands out with its clean lines and modern shed roof. This design makes the perfect poolhouse, studio, or garden shed!

If you're looking for a reliable and spacious storage solution, the NEW HAVEN is an excellent option. With its classic roof design, this structure will be a standout addition to your property and will impress anyone who sees it.

Our fourth and last design in this collection is the CAMDEN. This classic-style pavilion will make your backyard the envy of the neighborhood with its simple yet classic elegance.



SIMPLICITY BUILT RIGHT





# Jackson

## OPTIONS

ON THIS 10x14  
 Bronze Metal Roofing  
 #200 5' Double Doors  
 Square Cut Trim  
 Smoke / Bronze

### BASE PRICE UNIT

HOW IT'S BUILT

#### BUILDING HEIGHTS

- 8' W = 9' 8"
- 10' W = 10' 1"
- 12' W = 10' 6"
- 14' W = 11' 1"
- 16' W = 11' 6"







# Addison

## OPTIONS

ON THIS 10x12  
 Black Metal Roofing  
 #202-TW 5' Double Doors  
 Square Cut Trim  
 Pioneer / Ebony

### BASE PRICE UNIT HOW IT'S BUILT







# New Haven

## OPTIONS

ON THIS 10x14  
 Driftwood Shingles  
 #200 5' Double Doors  
 2'x3' Windows  
 Square Cut Trim  
 Khaki / Navajo White / Bronze

## BASE PRICE UNIT

HOW IT'S BUILT

### BUILDING HEIGHTS

- 8' W = 10' 3"
- 10' W = 11'
- 12' W = 11' 9"
- 14' W = 12' 6"
- 16' W = 13' 3"







## OPTIONS

ON THIS 12x14  
 Black Dimensional Shingles  
 Clay

# Camden

## BASE PRICE MODEL

Solid Pine 6x6 Posts  
 Smartside Gable Panels & Ceiling  
 Dimensional Shingles  
 Miratech Trim  
 5/12 Roof Pitch

## SIZES & POST LAYOUTS

*These sizes are outside of post to outside of post.*



### SIZES IN THIS CONFIGURATION

10x10	12x14
10x12	12x16
10x16	14x14
12x12	14x16

## SPECIFICATIONS

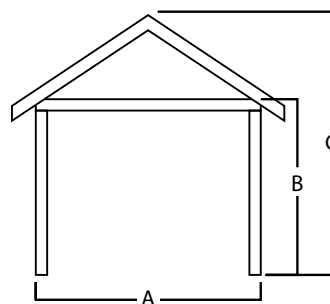

A	B	C
10'	7'4"	10' 2"
12'	7'4"	10' 7"
14'	7'4"	11' 0"

### OVERHANG DIMENSIONS

8" Overhangs on Eave  
 12" Overhangs on Gable





# BACKYARD LIVING





## SIZES & POST LAYOUTS

These sizes are outside of post to outside of post.



4 POST

10x10 12x16  
10x12 14x14  
10x16 14x16  
12x12 16x16  
12x14

## SPECIFICATIONS

width	height
10'	8'
12'	8'
14'	8'
16'	8'

OVERHANG DIMENSIONS  
12" Overhangs



**OPTIONS**  
ON THIS 12x12  
Smoke

# Laredo

Big, bold timbers and elegant accents make the LAREDO pergola a perfect addition to your outdoor living space. For extra wow factor, add it to a pavilion and create a dual-zone, outdoor entertainment area.

## HOW ITS MADE

Solid Cedar 8x8 Posts  
Solid Beams  
Purlins / Rafters  
Shade Slats

## SIZES & POST LAYOUTS

These sizes are outside of post to outside of post.



4 POST

10x10 12x16  
10x12 14x14  
10x16 14x16  
12x12 16x16  
12x14

## SPECIFICATIONS

width	height
10'	8'
12'	8'
14'	8'
16'	8'



**OPTIONS**  
ON THIS 12x16  
Bronze

# Montecito

A clean and modern pergola, the MONTECITO creates a wonderful environment for your outdoor space.

## HOW ITS MADE

Solid Cedar 8x8 Posts  
Solid Cedar Beams  
Solid Cedar Roof Slats  
Metal Brackets





#### OPTIONS

ON THIS 12x16  
Bronze Metal Roof  
Driftwood



# Timber Ridge

Available In Solid Pine Or Cedar

Beautiful timber framing in a timeless design makes the TIMBER RIDGE pavilion perfect in any setting. Large, rustic, solid-wood beams and rafters define this beautiful structure's style and quality.

#### BASE PRICE MODEL STANDARD FEATURES

Rough-Sawn Solid 8x8 Posts  
Rough-Sawn Solid Carrier Beams  
Rough-Sawn Solid A-Frame Gables  
Y-Support Bracing  
8/12 Pitch Roof  
Minimum 4x6 Rafters 24" O.C.  
1x8 Tongue and Groove Ceiling  
CDX Plywood Roof Sheathing  
Aluminum Drip Edge  
Dimensional Shingles  
Exposed Rafter Ceiling



## BRACKET CHOICES



CURVED



STRAIGHT

## SIZES & POST LAYOUTS

*These sizes are outside of post to outside of post.*



4 POST

### SIZES IN THIS CONFIGURATION

10x10 12x14 16x16  
10x12 12x16  
10x16 14x14  
12x12 14x16



6 POST

### SIZES IN THIS CONFIGURATION

12x20 14x28  
12x24 16x20  
14x20  
14x24



8 POST

### SIZES IN THIS CONFIGURATION

14x32 20x20  
16x24 20x24  
16x28 20x28  
16x32

## SPECIFICATIONS

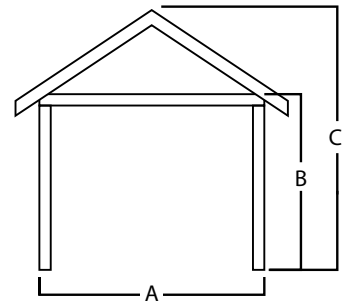

A	B	C
10'	8'	11' 10"
12'	8'	12' 6"
14'	8'	13' 4"
16'	8'	14'
20'	8'	15' 7"

### OVERHANG DIMENSIONS

12" Overhangs on Eave  
20" Overhangs on Gable





**OPTIONS**

ON THIS 12x16  
Driftwood Dimensional Shingles  
Pecan



# Bradford

Available In Solid Pine Or Cedar

With bold, rustic, rough-sawn beams and a classic hip roof, the BRADFORD is timeless in its design. A wonderful addition to a backyard or a pool side, you will love this beautiful structure.

**BASE PRICE MODEL**  
STANDARD FEATURES

- Rough-Sawn Solid 8x8 Posts
- Rough-Sawn Solid Carrier Beams
- Y-Support Bracing
- 7/12 Roof Pitch
- Minimum 4x6 Rafters 24" O.C.
- 1x8 Tongue and Groove Ceiling
- CDX Plywood Roof Sheathing
- Aluminum Drip Edge
- Dimensional Shingles
- Exposed Rafter Ceiling



## BRACKET CHOICES



CURVED



STRAIGHT

## SIZES & POST LAYOUTS

*These sizes are outside of post to outside of post.*



**4 POST**

### SIZES IN THIS CONFIGURATION

10x10 12x14 16x16  
 10x12 12x16  
 10x16 14x14  
 12x12 14x16



**6 POST**

### SIZES IN THIS CONFIGURATION

12x20 14x32  
 12x24 16x20  
 14x20 16x24  
 14x24 16x28  
 14x28 16x32



**8 POST**

### SIZES IN THIS CONFIGURATION

20x20  
 20x24  
 20x28  
 20x32

## SPECIFICATIONS

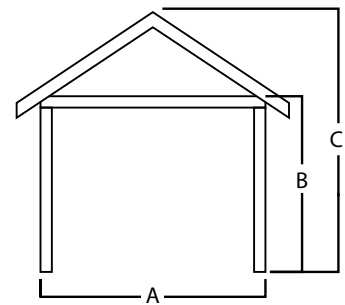

A	B	C
10'	8'	11' 6"
12'	8'	12' 1"
14'	8'	12' 10"
16'	8'	13' 5"
20'	8'	14' 9"

OVERHANG DIMENSIONS  
 12" Overhangs





**OPTIONS**

ON THIS 12x16  
Bronze Metal Roofing  
Natural / Chestnut Brown



# Lakewood

Available In Solid Pine Or Cedar

Mixing classic timber construction with a contemporary one-sided roof makes the LAKEWOOD one of a kind. A standard open-concept makes this pavilion perfect for you to enjoy with your friends and family.

**BASE PRICE MODEL**  
STANDARD FEATURES

- Rough-Sawn Solid 8x8 Posts
- Rough-Sawn Solid Carrier Beams
- Y-Support Bracing
- 2.5/12 Roof Pitch
- Minimum 4x8 Rafters 24" O.C.
- 1x8 Tongue and Groove Ceiling
- CDX Plywood Roof Sheathing
- Steel Drip Edge
- Metal Roof
- 12" Overhangs



## STRUCTURE OPTIONS

OPEN BACK  
STANDARD MODEL



CLOSED CEILING  
5% UPCHARGE



BACK & SIDE WALLS  
OPTIONAL WITH UPCHARGE



## SIZES & POST LAYOUTS

*These sizes are outside of post to outside of post.*



SIZES IN THIS CONFIGURATION

12x14  
12x16  
12x18  
14x16  
14x18



SIZES IN THIS CONFIGURATION

12x24  
12x28  
14x24  
14x26  
14x30

## SPECIFICATIONS

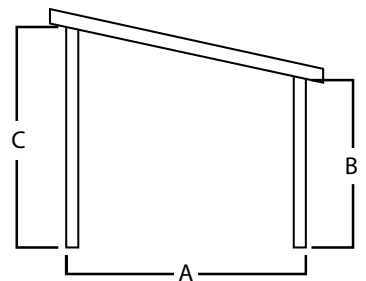

A	B	C
10'	7' 4"	10' 4"
12'	7' 4"	10' 9"
14'	7' 4"	11' 2"
16'	7' 4"	11' 7"

OVERHANG DIMENSIONS  
12" Overhangs





# Vinyl

## OPTIONS

ON THIS 12x16  
 Curved Brackets  
 Black Metal Roof

## BASE PRICE MODEL STANDARD FEATURES (VINYL)

Vinyl Wrapped 8x8 Posts  
 Cellular PVC Wrapped Carrier Beams  
 Cellular PVC Soffit & Fascia  
 7/12 Roof Pitch  
 2x6 Rafters 24" O.C.  
 1x8 Tongue and Groove Ceiling  
 CDX Plywood Roof Sheathing  
 Aluminum Drip Edge  
 Dimensional Shingles

# Dublin

Available In Pine, Cedar & Vinyl

Everyone loves beautiful outdoor spaces. The DUBLIN, with its flush ceiling, exposed posts, and beam details, makes it the perfect structure to make a statement in your backyard. Personalize this structure with beautiful bracket choices.



# Wood

## OPTIONS

ON THIS 12x16  
 Bronze Metal Roof  
 Smoke / Natural

## BASE PRICE MODEL STANDARD FEATURES (WOOD)

Rough-Sawn Solid 8x8 Post's  
 Y-Support Bracing  
 7/12 Roof Pitch  
 1x8 Tongue and Groove ceiling  
 CDX Plywood Roof Sheathing  
 Aluminum Drip Edge  
 Dimensional Shingles



## VINYL BRACKET CHOICES



**CURVED**

\*ADDITIONAL COST  
(VINYL ONLY)



**ARCHED**

\*ADDITIONAL COST  
(VINYL ONLY)

## VINYL SIZES & POST LAYOUTS

*These sizes are outside of post to outside of post.*



**SIZES IN THIS CONFIGURATION**

10x10 12x14 16x16  
10x12 12x16 20x20  
10x16 14x14  
12x12 14x16



**SIZES IN THIS CONFIGURATION**

12x20 16x24  
12x24 16x28  
14x20 16x32  
14x24 20x24  
14x28 20x28  
14x32 20x32  
16x20

## SPECIFICATIONS

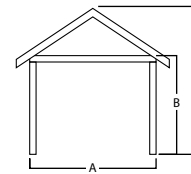

**VINYL**

A	B	C
10'	9'	12' 3"
12'	9'	13' 1"
14'	9'	13' 8"
16'	9'	14' 3"
20'	9'	15' 5"

**WOOD**

A	B	C
10'	8'	11' 8"
12'	8'	12' 5"
14'	8'	13'
16'	8'	13' 9"
20'	8'	14' 11"

**OVERHANG DIMENSIONS**  
8" Overhangs

## WOOD SIZES & POST LAYOUTS

*These sizes are outside of post to outside of post.*



**SIZES IN THIS CONFIGURATION**

10x10 12x14 16x16  
10x12 12x16  
10x16 14x14  
12x12 14x16



**SIZES IN THIS CONFIGURATION**

12x20 14x32  
12x24 16x20  
14x20 16x24  
14x24 16x28  
14x28 16x32



**SIZES IN THIS CONFIGURATION**

20x20  
20x24  
20x28  
20x32



# POST OPTIONS

Add accents to your wood post structures or change post colors on a vinyl structure.

## WOOD POST OPTIONS



STANDARD  
WOOD  
POST



OPTIONAL  
SMOOTH  
PINE  
\*LIMITED  
COLORS



OPTIONAL  
BASE  
WOOD  
ACCENT

## VINYL POST OPTIONS



STANDARD  
WHITE  
VINYL  
SLEEVE

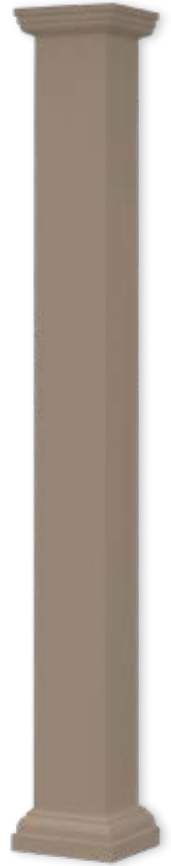

OPTIONAL  
CLAY  
VINYL  
SLEEVE

## WOOD BASE ACCENT



## 3' POST WRAP





# INSTALLATION METHODS

## DURA COLUMN POST SYSTEM

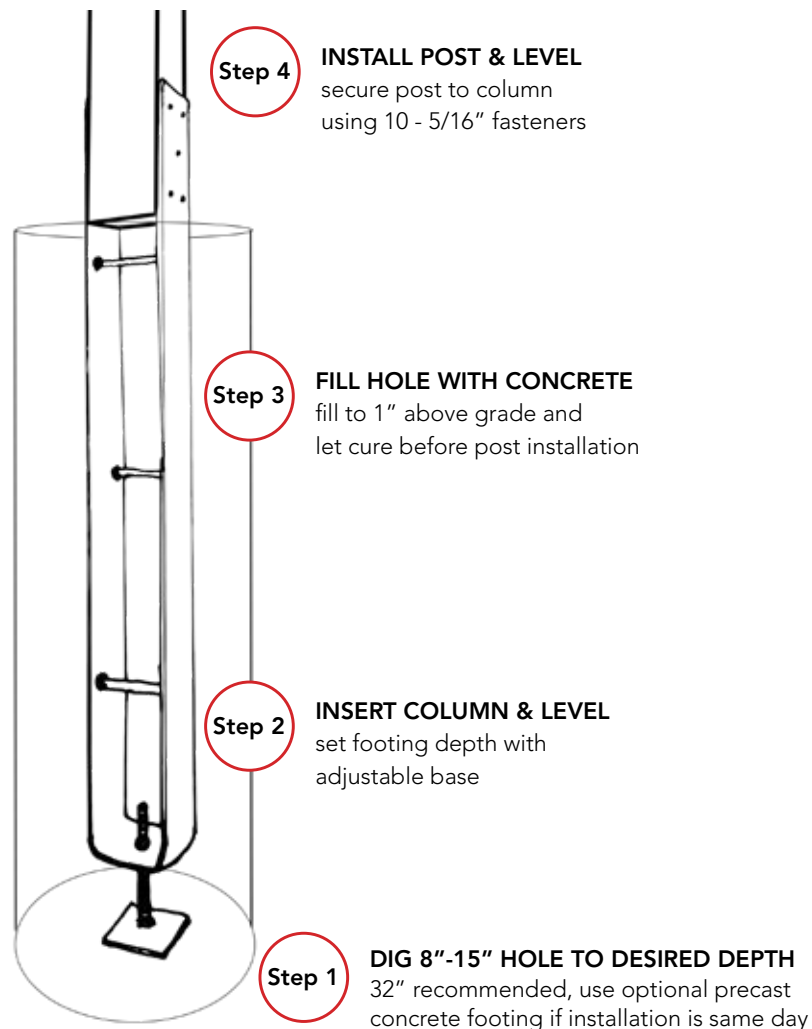

## METAL POST ANCHOR BRACKET

### POST ABOVE GRADE

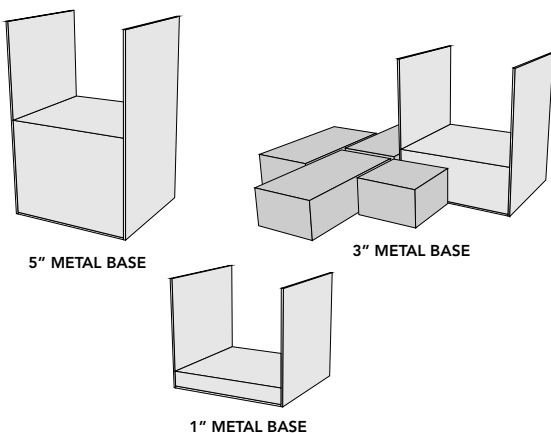

### OUR INCLUDED INSTALLATION METHOD

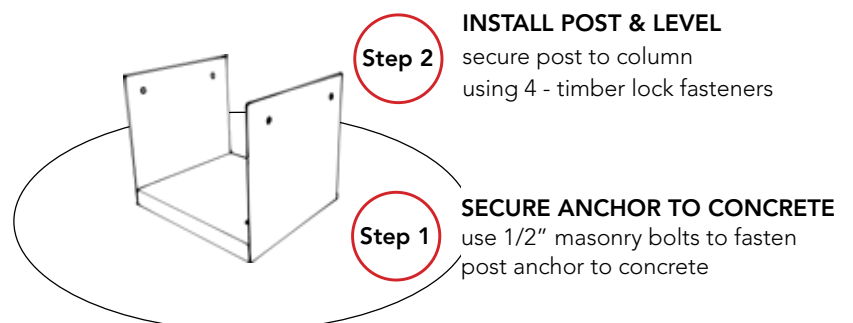



# GARAGES

Looking for a garage? Discover the process.

## Step 1 - WHAT SIZE?

### WHAT SIZE DO I NEED?

The first step in your design journey begins with size. What will you need to store, and what would you like to do with the space? Answering these questions early will save you time, money, and energy.

Layout Size Ideas

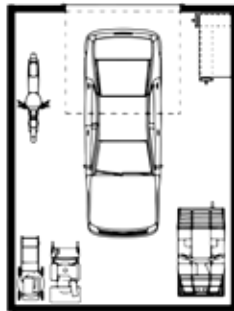

18x24 ONE CAR 432 Sq. Ft.

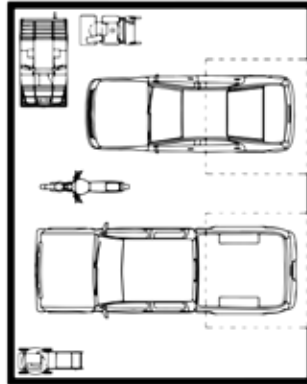

24x30 TWO CAR 720 Sq. Ft.

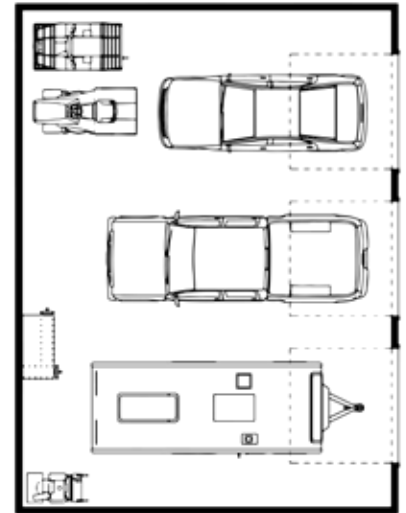

30x40 THREE CAR 1200 Sq. Ft.

## Step 2 - DESIGN OPTIONS?



### NOT THE LOOK YOU WANT?

All of our models are base designs. We fully expect you to design the project to your ideas. Use our models as a basic concept, but don't limit yourself. As a full custom builder, we turn your dreams into reality.



## Step 3 - WHAT FOUNDATION TYPE?

### Block Foundation

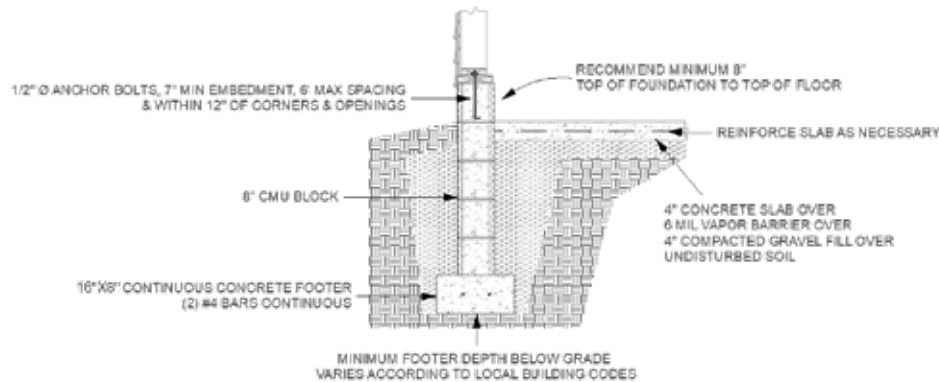

### Mono Pour Foundation

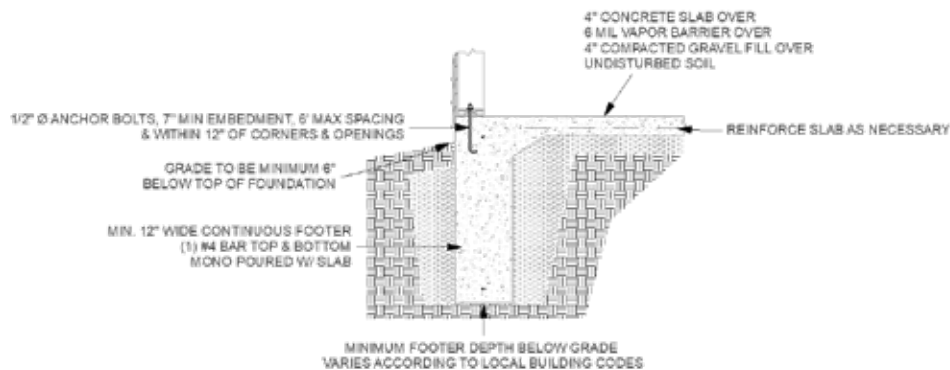

## Step 4 - PERMITS?

Weaver Barns builds in several different States. We ask the customer to be involved and pull the permits on projects that require that. However, we can provide the permit drawings and technical details required. Not all projects require permits, so please inquire with local building, zoning, HOAs or any regulatory agency in your area.



## Step 5 - CONSTRUCTION PROCESS

Once you have these steps completed, you will be ready for construction to begin. Our team will help guide you throughout this process, and make it as smooth as possible. In construction, variables are to be expected. Factors like weather and other delays play a large role in meeting project milestones. We do our best to work around these obstacles and be as efficient as possible.





# Gable Garage

OPTIONS ON THIS 12x20

2'x4' Windows  
Teak Dimensional Shingles  
Windows in Garage Door  
Chestnut Brown / Buckskin



## GABLE GARAGE ESTIMATE MATRIX



### Basic

Size: 14 x 24  
Painted Duratemp Siding  
1 – 10x7 Insulated Garage Door  
1 – 9-Lite Steel Entry Door  
2 – 2x4 Aluminum Windows  
10x5 Garage Door Ramp  
Dimensional Shingles  
2x8 T&G Floor on 4x6 Runners

Estimated Price **\$14,950**  
+ Foundation & Concrete (Contact Sales)



### Deluxe

Size: 14 x 24  
Painted Duratemp Siding  
1 – 10x7 Insulated Garage Door  
1 – 9-Lite Steel Entry Door  
2 – 2x4 Aluminum Windows  
10x5 Garage Door Ramp  
Dimensional Shingles  
2x8 T&G Floor on 4x6 Runners

Estimated Price **\$18,950**  
+ Foundation & Concrete (Contact Sales)



### Ultimate

Size: 16 x 32  
Dutch Lap Vinyl Siding  
1 – 12x7 Carriage House Door  
1 – 9-Lite Entry Door  
4 – 2x4 Vinyl Windows  
9' Sidewalls  
7/12 Roof Pitch  
Door Awnings  
Legacy Panel Metal Roof  
Wood Floor Credit

Estimated Price **\$32,900**  
+ Foundation & Concrete (Contact Sales)



# Gable Garage



## BASE PRICE UNIT

HOW IT'S BUILT

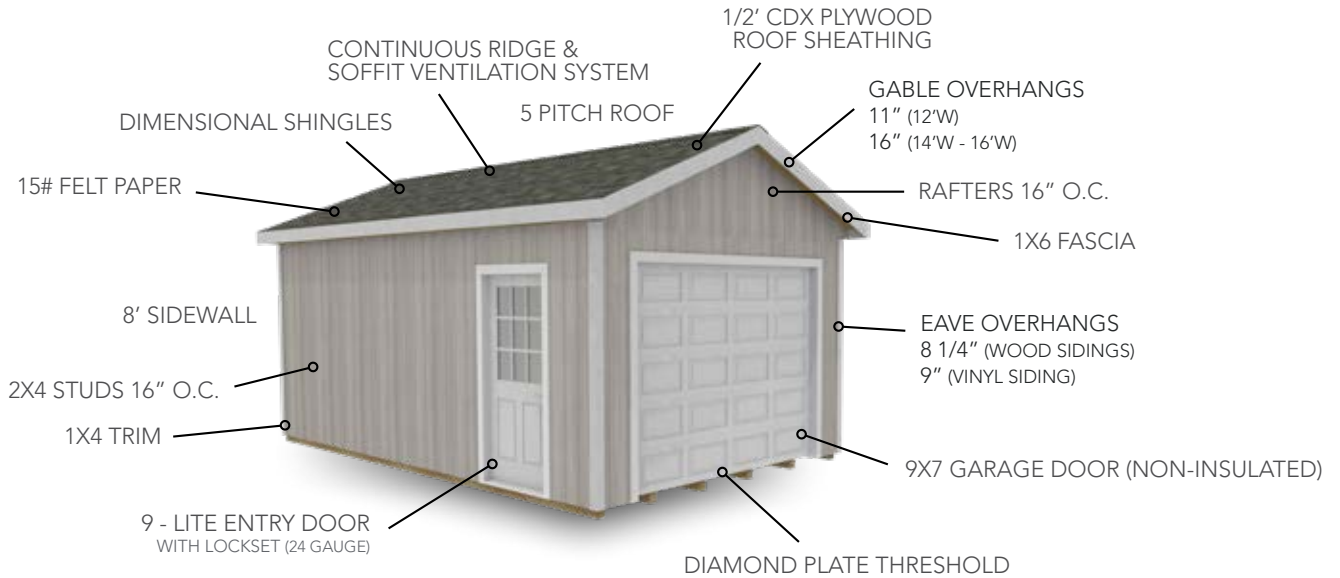

### INFORMATION

\*free delivery for 30 miles, delivery charges may apply beyond 30 miles

#### BUILDING HEIGHTS

12' Wide = 11' 7" High  
 14' Wide = 12' 0" High  
 16' Wide = 12' 5" High



## SIDING CHOICES

view pricing guide for current pricing

<p><b>SMARTSIDE LAP SIDING</b></p> <p>50-YEAR LIMITED WARRANTY</p> <ul style="list-style-type: none"> <li>Natural Woodgrain Texture</li> <li>100% Clear</li> <li>Pre-Primed</li> <li>50-Year Limited Warranty</li> </ul>	<p><b>VINYL SIDING</b></p> <ul style="list-style-type: none"> <li>Maintenance Free</li> <li>D44 Thickness</li> <li>Match Your Home</li> <li>CDX Plywood Subsidizing</li> </ul>	<p><b>PINE SIDING</b></p> <ul style="list-style-type: none"> <li>1 x 8 Premium-Grade Pine Siding</li> <li>Exclusive Rough-Sawn Finish</li> <li>Aesthetically Pleasing</li> <li>Tongue &amp; Groove</li> </ul>	<p><b>BOARD &amp; BATTEN</b></p> <p>50-YEAR LIMITED WARRANTY</p> <ul style="list-style-type: none"> <li>Natural Woodgrain Texture</li> <li>100% Clear</li> <li>Pre-Primed</li> <li>50-Year Limited Warranty</li> </ul>	<p><b>DURATEMP SIDING</b></p> <p>50-YEAR LIMITED WARRANTY</p> <ul style="list-style-type: none"> <li>Natural Woodgrain Texture</li> <li>100% Clear</li> <li>Pre-Primed</li> <li>50-Year Limited Warranty</li> </ul>	<p><b>SMARTSIDE SIDING</b></p> <p>50-YEAR LIMITED WARRANTY</p> <ul style="list-style-type: none"> <li>Natural Woodgrain Texture</li> <li>100% Clear</li> <li>Pre-Primed</li> <li>50-Year Limited Warranty</li> </ul>
--	--	---	--	---	--



# Workshop

## OPTIONS ON THIS 18x24

12'x7' Carriage House Door  
2'x4' Aluminum Windows  
Driftwood Shingles

Natural Cedar Shakes  
Windows in Garage Door  
Timber Frame Bracket  
Painted Clay / White



## WORKSHOP ESTIMATE MATRIX



### Basic

Size: 16 x 20  
Painted Smartside Siding  
1 - 12'x7' Garage Doors  
1 - 6 Panel Steel Door  
30 Year Shingle Roof  
Timber Frame Bracket  
8' Walls

Estimated Price **\$21,700**  
+ Foundation & Concrete (Contact Sales)



### Deluxe

Size: 18 x 24  
Painted Smartside Siding  
1 - 12'x7' Insulated Garage Doors  
1 - 6 Panel Steel Door  
30 Year Shingle Roof  
Timber Frame Bracket  
8' Walls  
2'x4' Aluminum Window  
Cedar Shakes

Estimated Price **\$27,400**  
+ Foundation & Concrete (Contact Sales)



### Ultimate

Size: 20 x 32  
Painted LP Lap Siding  
1 - 12'x7' Carriage Garage Doors  
1 - 9 Light Steel Door  
Metal Roof  
Cupola  
Timber Frame Bracket  
2'x4' + Transom Aluminum Windows  
Door Awning + Arbor

Estimated Price **\$43,900**  
+ Foundation & Concrete (Contact Sales)





## BASE PRICE UNIT

HOW IT'S BUILT

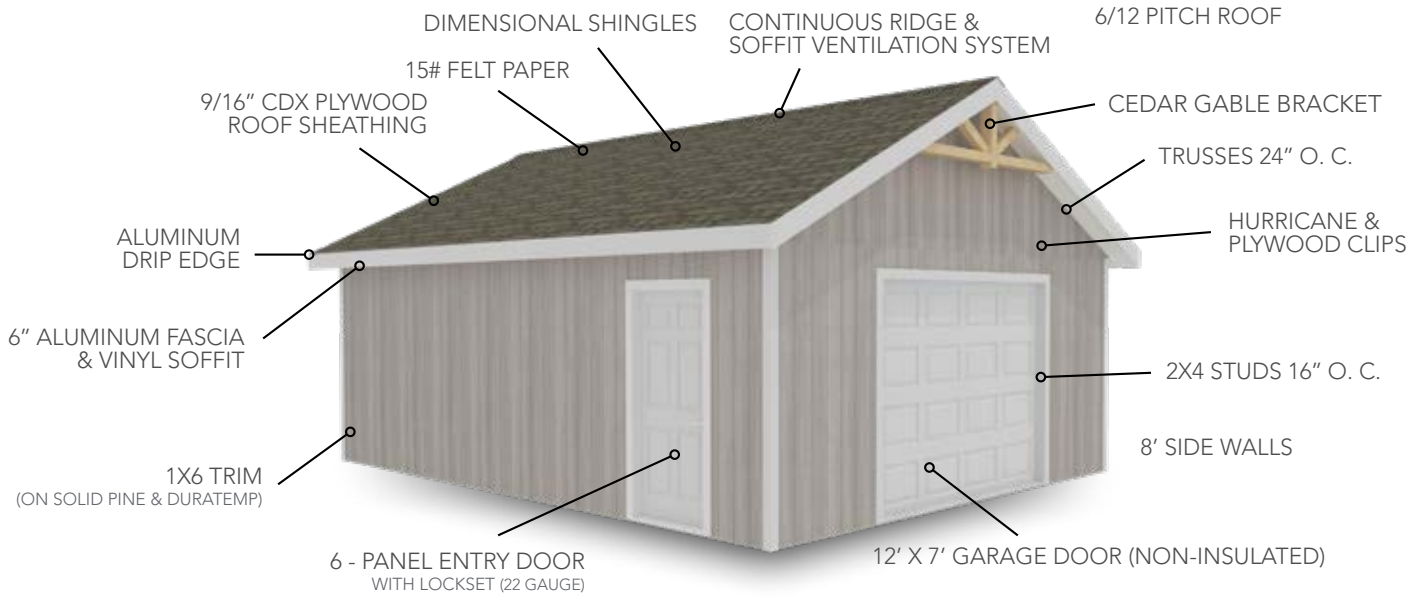

### INFORMATION

\*free delivery for 30 miles, delivery charges may apply beyond 30 miles

The Workshop is real property, NO additional sales tax is charged.

Floor is not included.

#### BUILDING HEIGHTS

16' Wide = 12' 6" High  
 18' Wide = 13' 0" High  
 20' Wide = 13' 6" High

GABLE OVERHANGS 16"  
 EAVE OVERHANGS 12"



## SIDING CHOICES view pricing guide for current pricing

<p><b>SMARTSIDE LAP SIDING</b></p> <p>50-YEAR LIMITED WARRANTY</p> <ul style="list-style-type: none"> <li>Natural Woodgrain Texture</li> <li>100% Clear</li> <li>Pre-Primed</li> <li>50-Year Limited Warranty</li> </ul>	<p><b>VINYL SIDING</b></p> <ul style="list-style-type: none"> <li>Maintenance Free</li> <li>D44 Thickness</li> <li>Match Your Home</li> <li>CDX Plywood Subsidizing</li> </ul>	<p><b>PINE SIDING</b></p> <ul style="list-style-type: none"> <li>1 x 8 Premium-Grade Pine Siding</li> <li>Exclusive Rough-Sawn Finish</li> <li>Aesthetically Pleasing</li> <li>Tongue &amp; Groove</li> </ul>	<p><b>BOARD &amp; BATTEN</b></p> <p>50-YEAR LIMITED WARRANTY</p> <ul style="list-style-type: none"> <li>Natural Woodgrain Texture</li> <li>100% Clear</li> <li>Pre-Primed</li> <li>50-Year Limited Warranty</li> </ul>	<p><b>DURATEMP SIDING</b></p> <p>50-YEAR LIMITED WARRANTY</p> <ul style="list-style-type: none"> <li>Natural Woodgrain Texture</li> <li>100% Clear</li> <li>Pre-Primed</li> <li>50-Year Limited Warranty</li> </ul>	<p><b>SMARTSIDE SIDING</b></p> <p>50-YEAR LIMITED WARRANTY</p> <ul style="list-style-type: none"> <li>Natural Woodgrain Texture</li> <li>100% Clear</li> <li>Pre-Primed</li> <li>50-Year Limited Warranty</li> </ul>
--	--	---	--	---	--



# The Classic

## OPTIONS ON THIS 24x32

- Estate Gray Dimensional Shingles
- 16'x7' Carriage House Door
- 3'x4' Vinyl Windows
- Vinyl Shutters
- Gutters and Downspouts
- Windows in Garage Door
- Pewter / White



## CLASSIC ESTIMATE MATRIX



### Two Car Basic

- Size: 24 x 24
- Painted Smartside Siding
- 2 - 9'x7' Uninsulated Garage Doors
- 1 - 9 Light Steel Door
- Dimensional Shingle Roof
- 8' Walls

Estimated Price **\$29,100**  
+ Foundation & Concrete (Contact Sales)



### Two Car Deluxe

- Size: 24 x 24
- Vinyl Siding
- 2 - 9'x7' Insulated Carriage Doors
- 2 - 3'x4' Vinyl Window
- 1 - 9 Light Steel Door
- Dimensional Shingle Roof
- 8' Walls
- 7/12 Pitch Roof Upgrade

Estimated Price **\$35,900**  
+ Foundation & Concrete (Contact Sales)



### Three Car Deluxe

- Size: 24 x 36
- Vinyl Siding
- 3- 9'x7' Insulated Carriage Doors
- 4 - 3'x4' Vinyl Window
- 1 - 9 Light Steel Door
- Dimensional Shingle Roof
- 9' Walls
- 8/12 Pitch Roof Upgrade

Estimated Price **\$52,900**  
+ Foundation & Concrete (Contact Sales)



# The Classic

Garages

## BASE PRICE UNIT

HOW IT'S BUILT

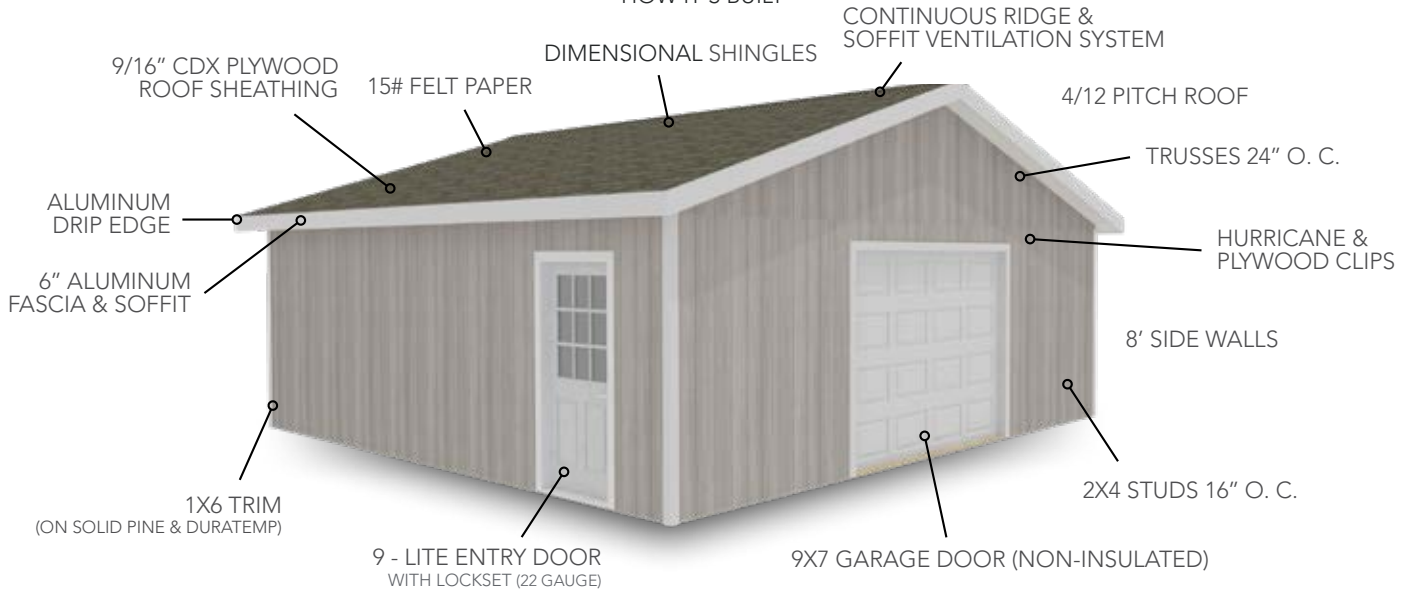

### INFORMATION

\*free delivery for 30 miles, delivery charges may apply beyond 30 miles

The Classic is real property, No additional sales tax charged.

Floor is not included.

#### BUILDING HEIGHTS

24' Wide = 12' 5" High  
30' Wide = 13' 5" High

GABLE OVERHANGS 16"  
EAVE OVERHANGS 12"



## SIDING CHOICES view pricing guide for current pricing

<p><b>SMARTSIDE LAP SIDING</b></p> <p>50-YEAR LIMITED WARRANTY</p> <ul style="list-style-type: none"> <li>Natural Woodgrain Texture</li> <li>100% Clear</li> <li>Pre-Primed</li> <li>50-Year Limited Warranty</li> </ul> <p><b>LP</b></p>	<p><b>VINYL SIDING</b></p> <ul style="list-style-type: none"> <li>Maintenance Free</li> <li>D44 Thickness</li> <li>Match Your Home</li> <li>CDX Plywood Subsidizing</li> </ul> <p><b>ProVia</b> HEARTTECH</p>	<p><b>PINE SIDING</b></p> <ul style="list-style-type: none"> <li>1 x 8 Premium-Grade Pine Siding</li> <li>Exclusive Rough-Sawn Finish</li> <li>Aesthetically Pleasing</li> <li>Tongue &amp; Groove</li> </ul> <p><b>LP</b></p>	<p><b>BOARD &amp; BATTEN</b></p> <p>50-YEAR LIMITED WARRANTY</p> <ul style="list-style-type: none"> <li>Natural Woodgrain Texture</li> <li>100% Clear</li> <li>Pre-Primed</li> <li>50-Year Limited Warranty</li> </ul> <p><b>LP</b></p>	<p><b>DURATEMP SIDING</b></p> <p>50-YEAR LIMITED WARRANTY</p> <ul style="list-style-type: none"> <li>Natural Woodgrain Texture</li> <li>100% Clear</li> <li>Pre-Primed</li> <li>50-Year Limited Warranty</li> </ul> <p><b>DuraTemp</b></p>	<p><b>SMARTSIDE SIDING</b></p> <p>50-YEAR LIMITED WARRANTY</p> <ul style="list-style-type: none"> <li>Natural Woodgrain Texture</li> <li>100% Clear</li> <li>Pre-Primed</li> <li>50-Year Limited Warranty</li> </ul> <p><b>LP</b></p>
---	---	--	---	--	---



# Heritage

## OPTIONS ON THIS 24x36

- 40" Traditional Cupola with Charcoal Metal Copper Eagle Weather Vane
- 2x4 with Transom Above Windows
- 2x3 Windows
- 9x7 Carriage House Garage Doors
- Charcoal Metal Roof
- Smartside Siding Painted
- Open Rafter Awnings
- 10' Sidewalls
- Painted Steel Entry Door
- Cultured Stone Wainscot
- Jamestown Red / Pecan / Clay



## HERITAGE ESTIMATE MATRIX



### Two Car Basic

- Size: 24 x 24
- Painted Smartside Siding
- 2 - 9'x7' Insulated Garage Doors
- 1 - 9 Light Steel Door
- Dimensional Shingle Roof
- 9' Walls
- Full Attic with Attic Pull Down Steps

Estimated Price \$41,700  
+ Foundation & Concrete (Contact Sales)



### Two Car Deluxe

- Size: 24 x 28
- Painted Smartside Siding
- 2 - 9'x7' Insulated Carriage Doors
- 3 - 2'x4' with Transom Above
- 3 - 2'x3' Aluminum Windows
- 1 - 9 Light Steel Door
- Metal Roof
- 9' Walls
- Full Attic With Steps And Landing
- Stone Accents & Open Rafter Awnings

Estimated Price \$57,500  
+ Foundation & Concrete (Contact Sales)



### Three Car Deluxe

- Size: 24 x 36
- Painted Duratemp Siding
- 2 - 9'x7' Insulated Carriage Doors
- 4 - 2'x4' with Transom Above
- 3 - 2'x3' Aluminum Windows
- 1 - 9 Light Steel Door
- Metal Roof - with Cupola & Weathervane
- 9' Walls
- Full Attic With Steps And Landing
- Stone Accents & Open Rafter Awnings

Estimated Price \$67,700  
+ Foundation & Concrete (Contact Sales)





## BASE PRICE UNIT

HOW IT'S BUILT

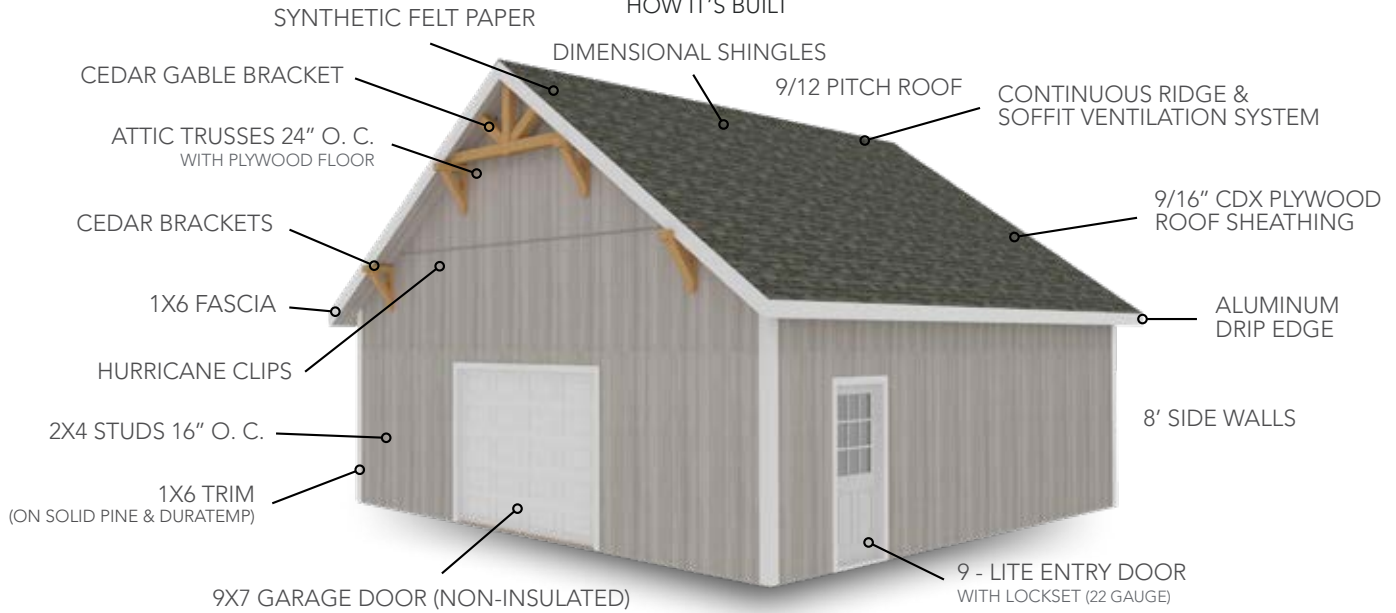

### INFORMATION

\*free delivery for 30 miles, delivery charges may apply beyond 30 miles

The Heritage is real property, NO additional sales tax charged.

Floor is not included.

### BUILDING HEIGHTS

20' Wide = 16' 2" High  
 24' Wide = 17' 8" High  
 30' Wide = 19' 11" High

GABLE OVERHANGS 16"  
 EAVE OVERHANGS 12"



## SIDING CHOICES view pricing guide for current pricing

<p><b>SMARTSIDE LAP SIDING</b></p> <p>50-YEAR LIMITED WARRANTY</p> <ul style="list-style-type: none"> <li>Natural Woodgrain Texture</li> <li>100% Clear</li> <li>Pre-Primed</li> <li>50-Year Limited Warranty</li> </ul>	<p><b>VINYL SIDING</b></p> <ul style="list-style-type: none"> <li>Maintenance Free</li> <li>D44 Thickness</li> <li>Match Your Home</li> <li>CDX Plywood Subsidizing</li> </ul>	<p><b>PINE SIDING</b></p> <ul style="list-style-type: none"> <li>1 x 8 Premium-Grade Pine Siding</li> <li>Exclusive Rough-Sawn Finish</li> <li>Aesthetically Pleasing</li> <li>Tongue &amp; Groove</li> </ul>	<p><b>BOARD &amp; BATTEN</b></p> <p>50-YEAR LIMITED WARRANTY</p> <ul style="list-style-type: none"> <li>Natural Woodgrain Texture</li> <li>100% Clear</li> <li>Pre-Primed</li> <li>50-Year Limited Warranty</li> </ul>	<p><b>DURATEMP SIDING</b></p> <p>50-YEAR LIMITED WARRANTY</p> <ul style="list-style-type: none"> <li>Natural Woodgrain Texture</li> <li>100% Clear</li> <li>Pre-Primed</li> <li>50-Year Limited Warranty</li> </ul>	<p><b>SMARTSIDE SIDING</b></p> <p>50-YEAR LIMITED WARRANTY</p> <ul style="list-style-type: none"> <li>Natural Woodgrain Texture</li> <li>100% Clear</li> <li>Pre-Primed</li> <li>50-Year Limited Warranty</li> </ul>
--	--	---	--	---	--



# Rockport

## OPTIONS ON THIS 32x24

- 2'x3' Vinyl Windows
- 3'x4' Vinyl Windows
- Stone Work
- Custom Cupola
- Onyx Black Dimensional Shingles
- Board & Batten Vinyl Siding
- 16'x7' Carriage House Door
- Windows in Garage Door 2'x3'



## ROCKPORT ESTIMATE MATRIX



### Two Car Basic

- Size: 24 x 20
- Painted Smartside Siding
- 1 - 16'x7' Insulated Garage Doors
- 1 - 9 Light Steel Door
- Loft with Attic Ladder
- 30 Year Shingle Roof
- 8' Walls

Estimated Price **\$40,200**  
+ Foundation & Concrete (Contact Sales)



### Two Car Deluxe

- Size: 32 x 24
- Vinyl Siding
- 1 - 16'x7' Insulated Carriage Doors
- 4 - 2'x3' Vinyl Window
- 1 - 9 Light Steel Door
- 30 Year Shingle Roof
- Loft with Attic Ladder
- 8' Walls
- 42" Stone Wainscot (2 Sides)

Estimated Price **\$62,100**  
+ Foundation & Concrete (Contact Sales)



### Three Car Deluxe

- Size: 40 x 30
- Vinyl Siding
- 1 - 16'x8'
- 1 - 10'x8'
- 4 - 2'x4' Vinyl SH
- Dimensional Shingles
- 3/4 Glass Entry
- 32" Stone Wainscot (2 Sides)
- 10' Walls
- Attic Truss w/ Loft & Ladder
- Cupola

Estimated Price **\$92,900**  
+ Foundation & Concrete (Contact Sales)





## BASE PRICE UNIT

HOW IT'S BUILT

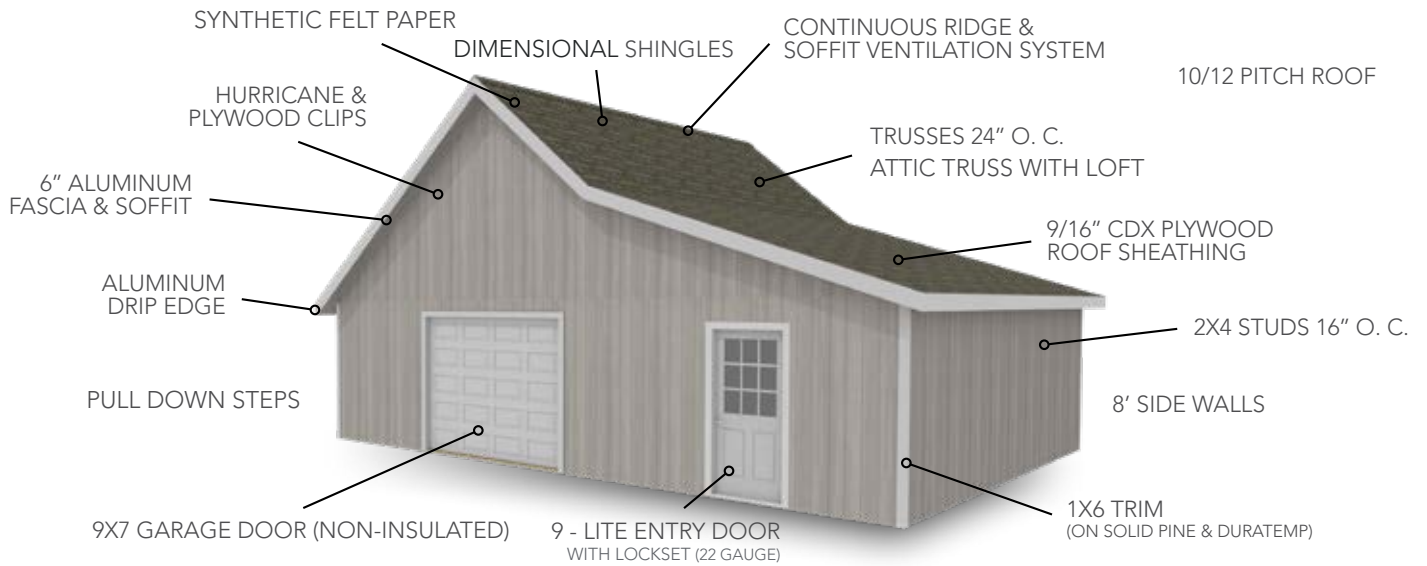

### INFORMATION

\*free delivery for 30 miles, delivery charges may apply beyond 30 miles

The Rockport is real property, No additional sales tax charged.

Floor is not included.

### BUILDING HEIGHTS

20' Wide = 17' 1" High  
 24' Wide = 18' 9" High  
 30' Wide = 21' 3" High

GABLE OVERHANGS 16"  
 EAVE OVERHANGS 12"



## SIDING CHOICES view pricing guide for current pricing

<p><b>SMARTSIDE LAP SIDING</b></p> <p>50-YEAR LIMITED WARRANTY</p> <ul style="list-style-type: none"> <li>Natural Woodgrain Texture</li> <li>100% Clear</li> <li>Pre-Primed</li> <li>50-Year Limited Warranty</li> </ul>	<p><b>VINYL SIDING</b></p> <ul style="list-style-type: none"> <li>Maintenance Free</li> <li>D44 Thickness</li> <li>Match Your Home</li> <li>CDX Plywood Subsidizing</li> </ul>	<p><b>PINE SIDING</b></p> <ul style="list-style-type: none"> <li>1 x 8 Premium-Grade Pine Siding</li> <li>Exclusive Rough-Sawn Finish</li> <li>Aesthetically Pleasing</li> <li>Tongue &amp; Groove</li> </ul>	<p><b>BOARD &amp; BATTEN</b></p> <p>50-YEAR LIMITED WARRANTY</p> <ul style="list-style-type: none"> <li>Natural Woodgrain Texture</li> <li>100% Clear</li> <li>Pre-Primed</li> <li>50-Year Limited Warranty</li> </ul>	<p><b>DURATEMP SIDING</b></p> <p>50-YEAR LIMITED WARRANTY</p> <ul style="list-style-type: none"> <li>Natural Woodgrain Texture</li> <li>100% Clear</li> <li>Pre-Primed</li> <li>50-Year Limited Warranty</li> </ul>	<p><b>SMARTSIDE SIDING</b></p> <p>50-YEAR LIMITED WARRANTY</p> <ul style="list-style-type: none"> <li>Natural Woodgrain Texture</li> <li>100% Clear</li> <li>Pre-Primed</li> <li>50-Year Limited Warranty</li> </ul>
--	--	---	--	---	--



# Willow Creek

## OPTIONS ON THIS 24x36

- 9'x7' Long Panel Carriage House Doors
- Timbers Stained Pioneer
- Textured Legacy Metal Roof
- Painted Steel Entry Door
- White Vinyl Board & Batten Siding
- Door Awning
- 8' Lean-To with RS Pine Timbers
- Black Vinyl Window Package
- 40" Traditional Cupola with Black Roof
- Copper Eagle Weather Vane



## WILLOW CREEK ESTIMATE MATRIX



### Two Car Basic

- Size: 20 x 24
- Painted Smartside Siding
- 1 - 16'x7' Insulated Garage Doors
- 1 - 9 Light Steel Door
- Shingle Roof
- 10' Walls
- Half Loft & Steps with Landing

Estimated Price **\$45,400**  
+ Foundation & Concrete (Contact Sales)



### Two Car Deluxe

- Size: 24 x 32
- Painted Smartside Siding
- 2 - 9'x7' Insulated Carriage Doors
- 4 - 2'x4' + 3 - 2'x3' Aluminum Windows
- 1 - 9 Light Steel Door
- Dimensional Shingle Roof
- 10' Walls
- Half Loft & Steps with Landing
- Awning

Estimated Price **\$65,100**  
+ Foundation & Concrete (Contact Sales)



### Three Car Deluxe

- Size: 24 x 36
- Stained Pine Siding
- 2 - 9'x7' Insulated Carriage Doors
- 5 - 2'x4' + 3 - 2'x3' Aluminum Windows
- 1 - 9 Light Steel Door
- 40 Year Metal Roofing + Cupola
- 10' Walls + 8' Lean-to
- Half Loft & Steps with Landing
- Awning

Estimated Price **\$90,400**  
+ Foundation & Concrete (Contact Sales)



## BASE PRICE UNIT

HOW IT'S BUILT

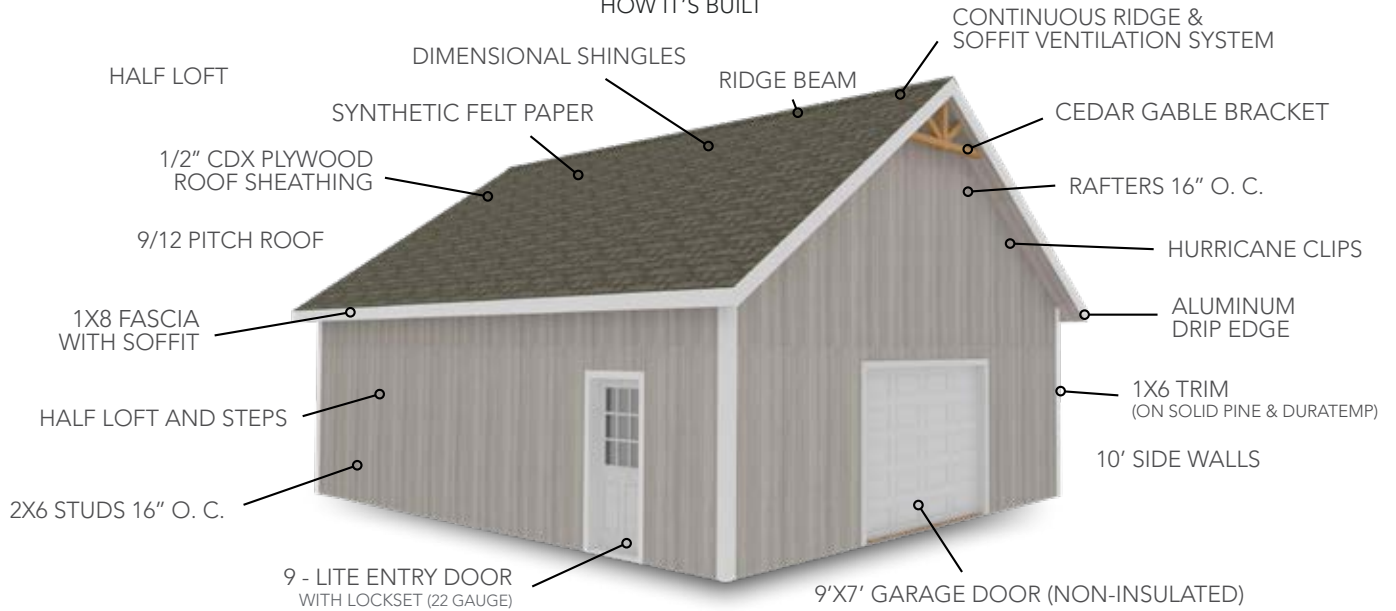

### INFORMATION

\*free delivery for 30 miles, delivery charges may apply beyond 30 miles

The Willow Creek is real property, NO additional sales tax charged.

Floor is not included.

### BUILDING HEIGHTS

20' Wide = 18' 2" High  
 24' Wide = 19' 8" High  
 30' Wide = 21' 11" High

GABLE OVERHANGS 16"  
 EAVE OVERHANGS 12"



## SIDING CHOICES view pricing guide for current pricing

### SMARTSIDE LAP SIDING

- 50-YEAR LIMITED WARRANTY
- Natural Woodgrain Texture
- 100% Clear
- Pre-Primed
- 50-Year Limited Warranty



### VINYL SIDING

- Maintenance Free
- D44 Thickness
- Match Your Home
- CDX Plywood Subsidizing



### PINE SIDING

- 1 x 8 Premium-Grade Pine Siding
- Exclusive Rough-Sawn Finish
- Aesthetically Pleasing
- Tongue & Groove



### BOARD & BATTEN

- 50-YEAR LIMITED WARRANTY
- Natural Woodgrain Texture
- 100% Clear
- Pre-Primed
- 50-Year Limited Warranty



### DURATEMP SIDING

- 50-YEAR LIMITED WARRANTY
- Natural Woodgrain Texture
- 100% Clear
- Pre-Primed
- 50-Year Limited Warranty



### SMARTSIDE SIDING

- 50-YEAR LIMITED WARRANTY
- Natural Woodgrain Texture
- 100% Clear
- Pre-Primed
- 50-Year Limited Warranty





# Cascade

## OPTIONS ON THIS 24x32

Black Metal Roofing  
 Custom Window Package  
 32' Awning

10x8 #360 Full Glass Garage Doors  
 Painted Full Glass Entry Door  
 SW Iron Ore / Black / Pecan



## CASCADE ESTIMATE MATRIX



### Two Car Basic

Size: 20 x 24  
 Painted LP Lap Siding  
 Metal Roof  
 1 - 16'x8' 5000 Series Garage Door  
 1 - Full Glass Entry Door

Estimated Price **\$46,100**  
 + Foundation & Concrete (Contact Sales)



### Two Car Deluxe

Size: 24 x 32  
 Painted LP Siding (*Lap and Board & Batten*)  
 2 - 18'x60' Black Vinyl Window  
 2 - 18'x40' Black Vinyl Window  
 2 - 18'x28' Black Vinyl Window  
 2 - 10'x8' #360 Full Glass Garage Doors  
 Full Glass Entry Door  
 Legacy Panel Metal Roof  
 32' Timber Awning

Estimated Price **\$80,300**  
 + Foundation & Concrete (Contact Sales)



### Three Car Deluxe

Size: 24 x 40  
 Painted LP Siding (*Lap and Board & Batten*)  
 3 - 20"x108" Black Vinyl Window  
 1 - 36"x50" Black Vinyl Window  
 3 - 10'x8' #360 Full Glass Garage Doors  
 Stained Fiberglass Entry Door  
 Legacy Panel Metal Roof  
 40' Timber Awning

Estimated Price **\$99,800**  
 + Foundation & Concrete (Contact Sales)



## BASE PRICE UNIT

HOW IT'S BUILT

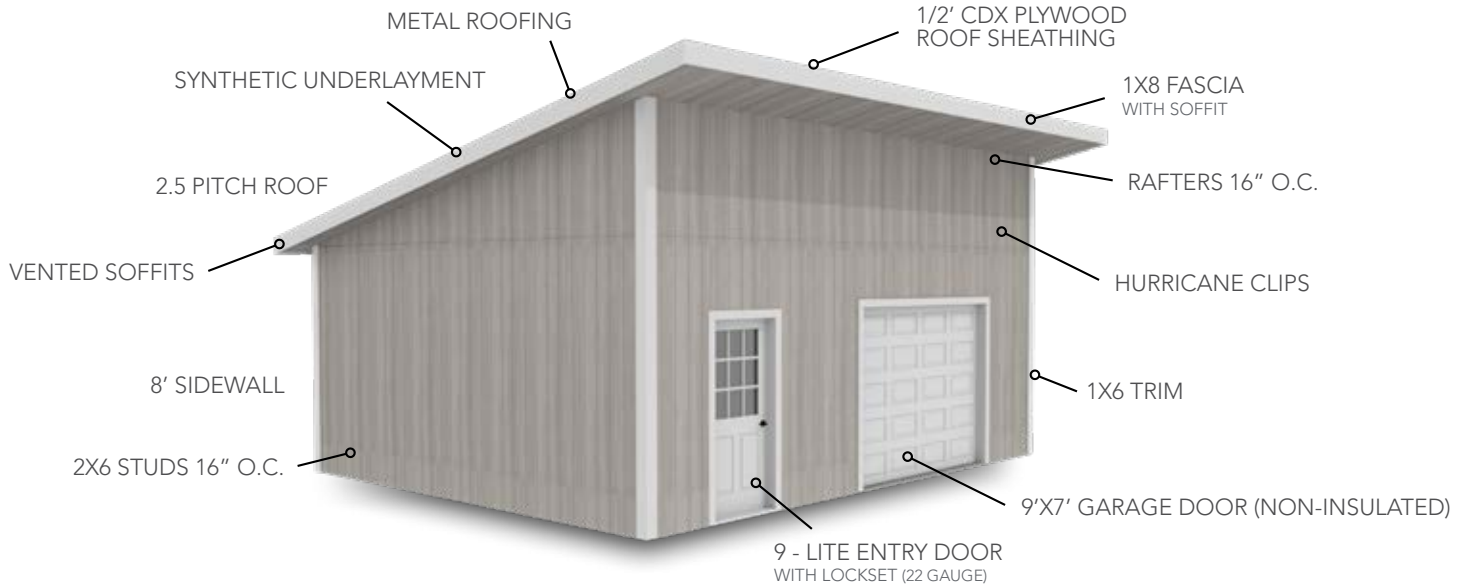

### INFORMATION

\*free delivery for 30 miles, delivery charges may apply beyond 30 miles

The Cascade is real property, NO additional sales tax charged.

Floor is not included.

### BUILDING HEIGHTS

20' Wide = 14' 1" High  
 24' Wide = 14' 11" High  
 28' Wide = 15' 9" High

BACK OVERHANGS 12"  
 FRONT OVERHANGS 36"  
 GABLE OVERHANGS 16"



## SIDING CHOICES view pricing guide for current pricing

<p><b>SMARTSIDE LAP SIDING</b></p> <p>50-YEAR LIMITED WARRANTY</p> <ul style="list-style-type: none"> <li>Natural Woodgrain Texture</li> <li>100% Clear</li> <li>Pre-Primed</li> <li>50-Year Limited Warranty</li> </ul>	<p><b>VINYL SIDING</b></p> <ul style="list-style-type: none"> <li>Maintenance Free</li> <li>D44 Thickness</li> <li>Match Your Home</li> <li>CDX Plywood Subsidizing</li> </ul>	<p><b>PINE SIDING</b></p> <ul style="list-style-type: none"> <li>1 x 8 Premium-Grade Pine Siding</li> <li>Exclusive Rough-Sawn Finish</li> <li>Aesthetically Pleasing</li> <li>Tongue &amp; Groove</li> </ul>	<p><b>BOARD &amp; BATTEN</b></p> <p>50-YEAR LIMITED WARRANTY</p> <ul style="list-style-type: none"> <li>Natural Woodgrain Texture</li> <li>100% Clear</li> <li>Pre-Primed</li> <li>50-Year Limited Warranty</li> </ul>	<p><b>DURATEMP SIDING</b></p> <p>50-YEAR LIMITED WARRANTY</p> <ul style="list-style-type: none"> <li>Natural Woodgrain Texture</li> <li>100% Clear</li> <li>Pre-Primed</li> <li>50-Year Limited Warranty</li> </ul>	<p><b>SMARTSIDE SIDING</b></p> <p>50-YEAR LIMITED WARRANTY</p> <ul style="list-style-type: none"> <li>Natural Woodgrain Texture</li> <li>100% Clear</li> <li>Pre-Primed</li> <li>50-Year Limited Warranty</li> </ul>
--	--	---	--	---	--



# Dutch Garage

## OPTIONS ON THIS 24x32

- Legacy Black Metal Roof
- 3'x4' SH Vinyl Window
- 2'x3' SH Vinyl Window
- Shutter Sets
- Cedar Vent
- 20' Open Rafter Awning
- 16'x8' Garage Door
- 10'x8' Sliding Barn Doors
- Painted 6' French Doors
- 9' Sidewall
- White/Pecan



## DUTCH GARAGE ESTIMATE MATRIX



### Two Car Basic

- Size: 24 x 24  
 Painted Smartside Siding  
 1 - 16'x8' Non-Insulated Garage Door  
 1 - 9 Light Steel Door  
 1 - 3'x4' Vinyl Window  
 1 - 2'x3' Vinyl Window  
 Cedar Shutters  
 9' Sidewall  
 Attic Truss + Loft + Pull Down Steps  
 Dimensional Shingles

Estimated Price **\$42,500**  
 + Foundation & Concrete (Contact Sales)



### Two Car Deluxe

- Size: 24 x 28  
 Painted Duratemp Siding  
 2 - 9'x8' Carriage House Doors  
 1 - 72" Full Glass Steel Doors  
 1 - 10'x8' Cedar Sliding Barn Doors  
 Open Rafter Awning  
 1 - 2'x4' Vinyl Window  
 Shutter Set  
 9' Sidewalls  
 3' Stone Wainscot (2 sides)  
 Legacy Panel Metal Roof  
 Attic Truss + Loft + Pull Down Steps

Estimated Price **\$61,300**  
 + Foundation & Concrete (Contact Sales)



### Three Car Deluxe

- Size: 24 x 36  
 Painted Board & Batten Siding  
 2 - 9'x8' Carriage House Doors  
 1 - 72" Full Glass Steel Doors  
 1 - 10'x8' Cedar Sliding Barn Doors  
 Open Rafter Awning  
 1 - 3'x4', 2'x4' Window  
 Shutter Sets  
 9' Sidewalls  
 3' Stone Wainscot (2 Sides)  
 Legacy Panel Metal Roof  
 Attic Truss With Steps and Landing + Railing

Estimated Price **\$78,100**  
 + Foundation & Concrete (Contact Sales)

# Dutch Garage



## BASE PRICE UNIT

HOW IT'S BUILT

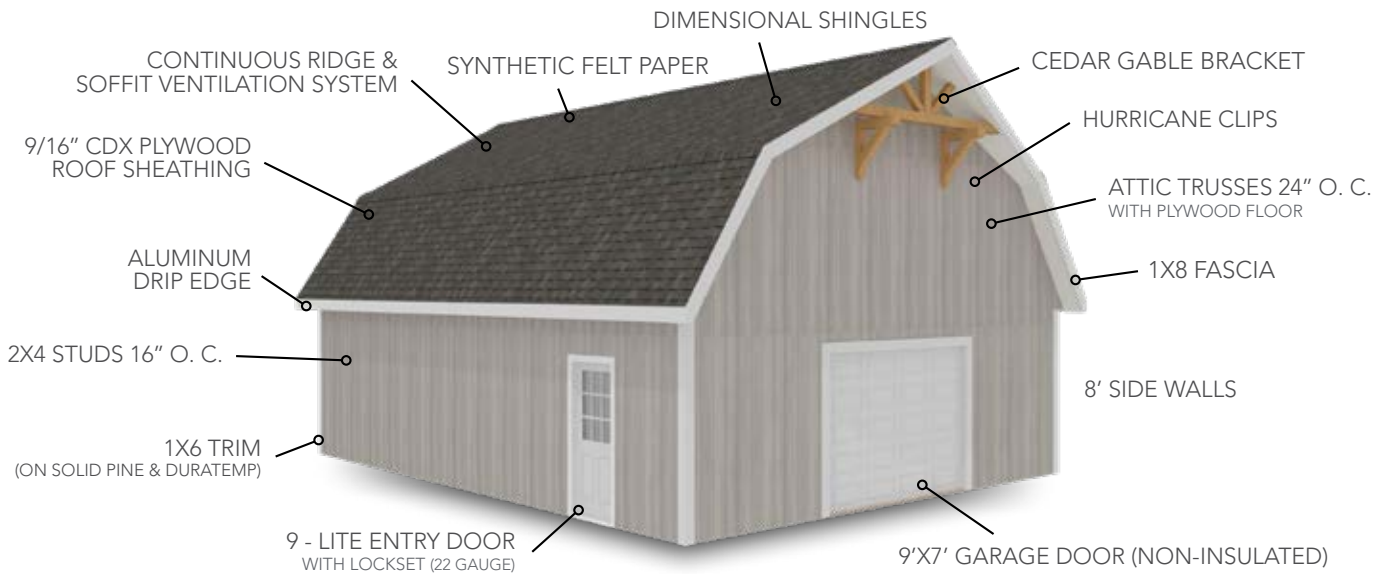

### INFORMATION

\*free delivery for 30 miles, delivery charges may apply beyond 30 miles

The Dutch is real property, NO additional sales tax charged.

Floor is not included.

**BUILDING HEIGHTS**  
 20' Wide = 17' 8" High  
 24' Wide = 19' 8" High

GABLE OVERHANGS 16"  
 EAVE OVERHANGS 12"



## SIDING CHOICES view pricing guide for current pricing

<p><b>SMARTSIDE LAP SIDING</b></p> <p>50-YEAR LIMITED WARRANTY</p> <ul style="list-style-type: none"> <li>Natural Woodgrain Texture</li> <li>100% Clear</li> <li>Pre-Primed</li> <li>50-Year Limited Warranty</li> </ul>	<p><b>VINYL SIDING</b></p> <ul style="list-style-type: none"> <li>Maintenance Free</li> <li>D44 Thickness</li> <li>Match Your Home</li> <li>CDX Plywood Subsidizing</li> </ul>	<p><b>PINE SIDING</b></p> <ul style="list-style-type: none"> <li>1 x 8 Premium-Grade Pine Siding</li> <li>Exclusive Rough-Sawn Finish</li> <li>Aesthetically Pleasing</li> <li>Tongue &amp; Groove</li> </ul>	<p><b>BOARD &amp; BATTEN</b></p> <p>50-YEAR LIMITED WARRANTY</p> <ul style="list-style-type: none"> <li>Natural Woodgrain Texture</li> <li>100% Clear</li> <li>Pre-Primed</li> <li>50-Year Limited Warranty</li> </ul>	<p><b>DURATEMP SIDING</b></p> <p>50 YEAR LIMITED WARRANTY</p> <ul style="list-style-type: none"> <li>Natural Woodgrain Texture</li> <li>100% Clear</li> <li>Pre-Primed</li> <li>50-Year Limited Warranty</li> </ul>	<p><b>SMARTSIDE SIDING</b></p> <p>50-YEAR LIMITED WARRANTY</p> <ul style="list-style-type: none"> <li>Natural Woodgrain Texture</li> <li>100% Clear</li> <li>Pre-Primed</li> <li>50-Year Limited Warranty</li> </ul>
--	--	---	--	---	--



# Dutch Barn

## OPTIONS ON THIS 24x32

- 10'x7' Double Sliding Door w/ Transoms
- Loft door w/ Transoms
- Onyx Black Dimensional Shingles
- Painted Steel Entry Door
- Custom Cupola
- 2'x3' Windows
- 6' Lean-To
- Mountain Red / White



## DUTCH BARN ESTIMATE MATRIX



### Basic Barn

- Size: 20 x 24
- Painted Smartside Siding
- 1 - 10'x7' Sliding Cedar Doors
- 1 - 9 Light Steel Door
- Painted Door
- Dimensional Shingle Roof
- 9' Walls
- Half Loft With Steps & Landing

Estimated Price **\$40,500**  
+ Foundation & Concrete (Contact Sales)



### Deluxe Barn

- Size: 24 x 32
- Painted Smartside Siding
- 1 - 10'x7' Sliding Cedar Doors
- 3 - 3'x4' Vinyl Window
- 1 - 9 Light Steel Door
- Dimensional Shingle Roof
- 9' Walls
- Half Loft & Steps with Landing
- 8' Lean-to

Estimated Price **\$64,900**  
+ Foundation & Concrete (Contact Sales)



### Ultimate Barn

- Size: 24 x 36
- Painted Duratemp Siding
- 1 - 10'x7' Sliding Cedar Doors
- 8 - 3'x4' Vinyl Window
- 1 - 9 Light Steel Door + Loft Door
- 40 Year Metal Roof + Cupola
- 9' Walls
- Half Loft & Steps with Landing
- 8' Lean-to

Estimated Price **\$76,500**  
+ Foundation & Concrete (Contact Sales)

# Dutch Barn

Garages



## BASE PRICE UNIT

HOW IT'S BUILT

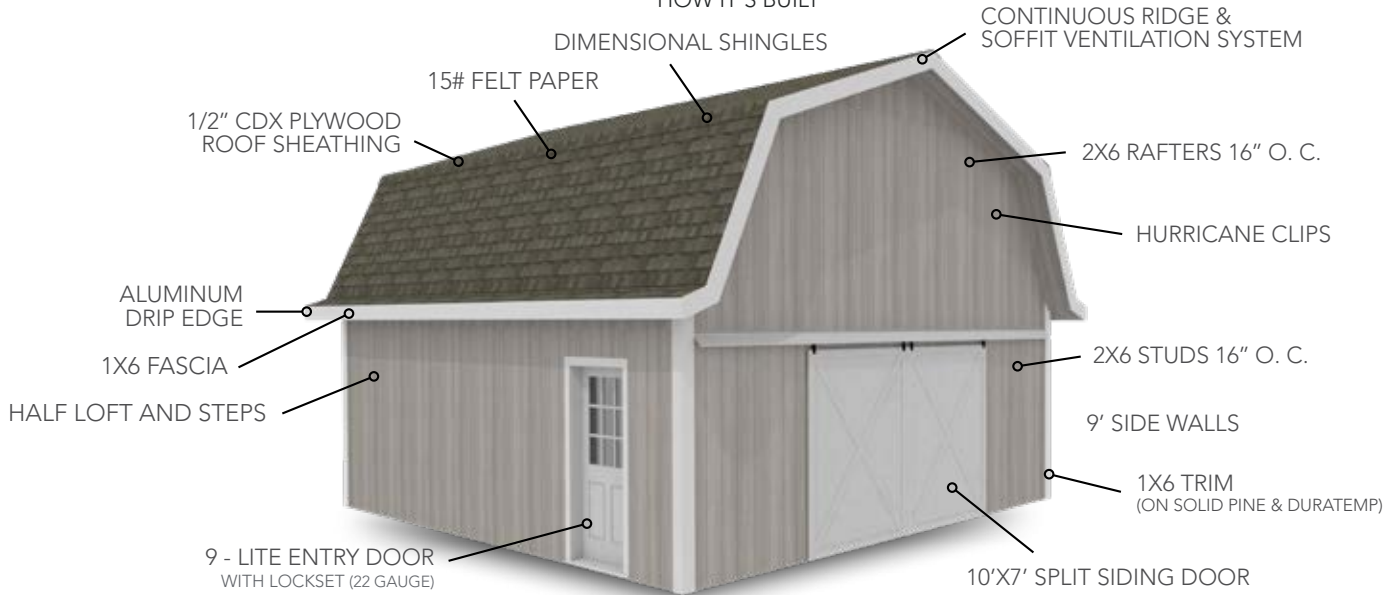

### INFORMATION

\*free delivery for 30 miles, delivery charges may apply beyond 30 miles

The Dutch is real property, NO additional sales tax charged.

Floor is not included.

#### BUILDING HEIGHTS

20' Wide = 16' 2" High  
 24' Wide = 17' 8" High  
 30' Wide = 19' 11" High

GABLE OVERHANGS 16"  
 EAVE OVERHANGS 7.25"



## SIDING CHOICES view pricing guide for current pricing

<p><b>SMARTSIDE LAP SIDING</b></p> <p>50-YEAR LIMITED WARRANTY</p> <ul style="list-style-type: none"> <li>Natural Woodgrain Texture</li> <li>100% Clear</li> <li>Pre-Primed</li> <li>50-Year Limited Warranty</li> </ul>	<p><b>VINYL SIDING</b></p> <ul style="list-style-type: none"> <li>Maintenance Free</li> <li>D44 Thickness</li> <li>Match Your Home</li> <li>CDX Plywood Subsidizing</li> </ul>	<p><b>PINE SIDING</b></p> <ul style="list-style-type: none"> <li>1 x 8 Premium-Grade Pine Siding</li> <li>Exclusive Rough-Sawn Finish</li> <li>Aesthetically Pleasing</li> <li>Tongue &amp; Groove</li> </ul>	<p><b>BOARD &amp; BATTEN</b></p> <p>50-YEAR LIMITED WARRANTY</p> <ul style="list-style-type: none"> <li>Natural Woodgrain Texture</li> <li>100% Clear</li> <li>Pre-Primed</li> <li>50-Year Limited Warranty</li> </ul>	<p><b>DURATEMP SIDING</b></p> <p>50-YEAR LIMITED WARRANTY</p> <ul style="list-style-type: none"> <li>Natural Woodgrain Texture</li> <li>100% Clear</li> <li>Pre-Primed</li> <li>50-Year Limited Warranty</li> </ul>	<p><b>SMARTSIDE SIDING</b></p> <p>50-YEAR LIMITED WARRANTY</p> <ul style="list-style-type: none"> <li>Natural Woodgrain Texture</li> <li>100% Clear</li> <li>Pre-Primed</li> <li>50-Year Limited Warranty</li> </ul>
--	--	---	--	---	--





# Frontier CABIN

## OPTIONS ON THIS 16x24

- Galvalume Metal Roofing
- 6' Timber Porch
- 10' Sidewalls
- Clay Window Package
- 14' Shed Dormers, Front & Back
- 9-Lite & 15-Lite Steel Doors, Painted
- 2x4 Interior Wall Framing
- Smoke / Black / Deep Ruby

## BASE PRICE UNIT

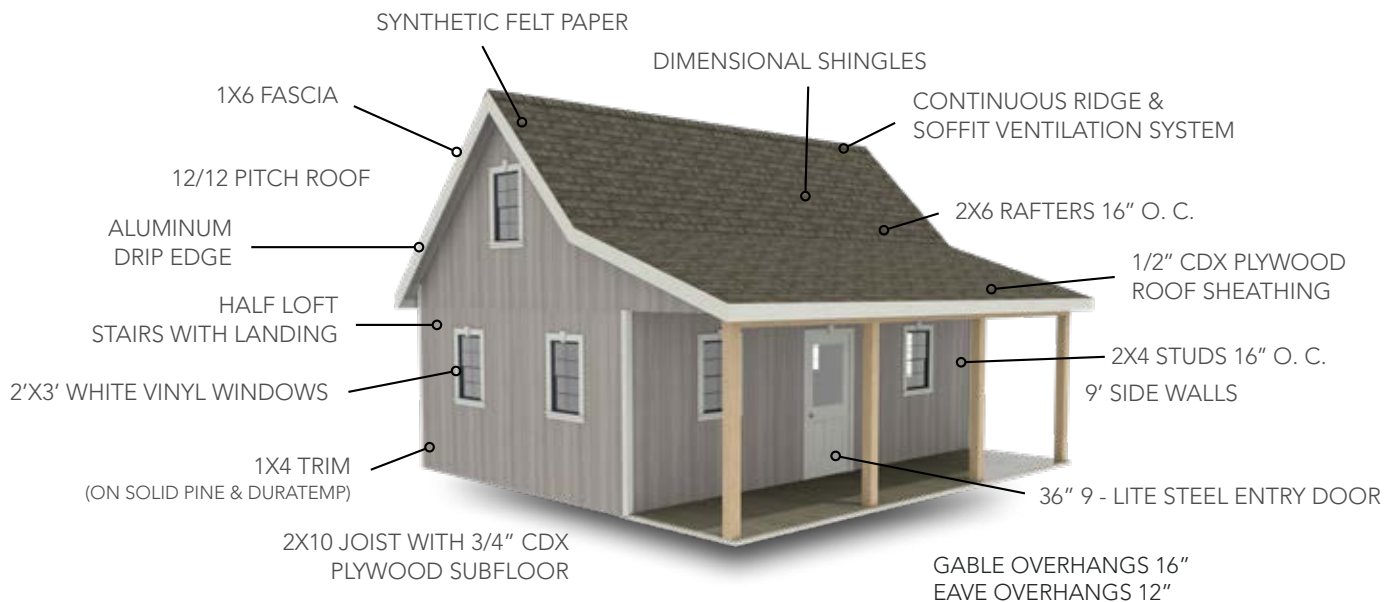

576 Sq. Ft.

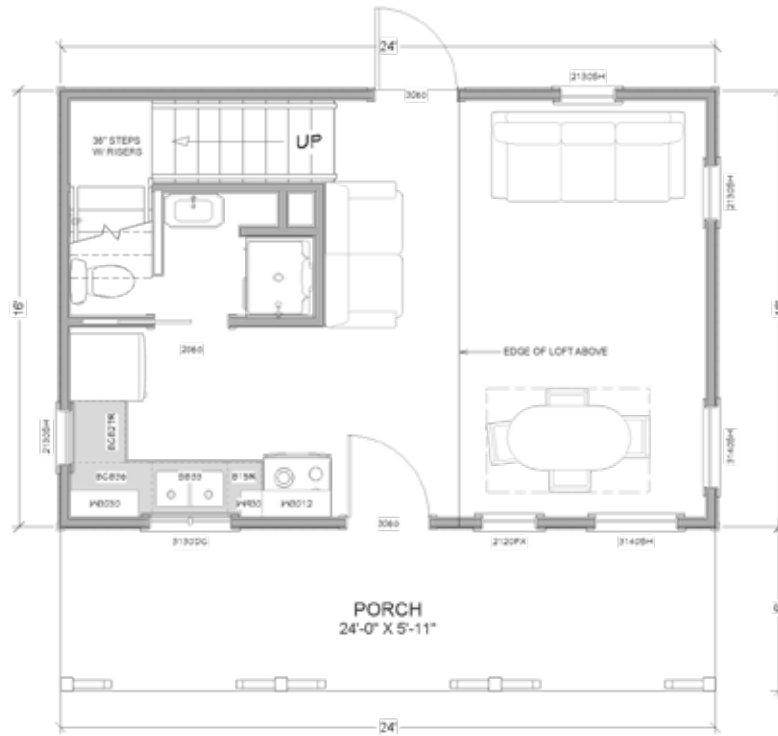

**Main Floor**



**2nd Floor**

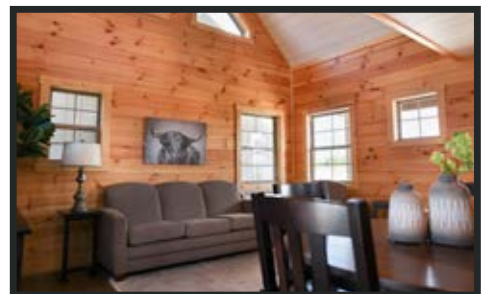





# Aspen CABIN

**OPTIONS ON THIS 20x26**  
 Black Window Package  
 Interior Wall Framing

## BASE PRICE UNIT

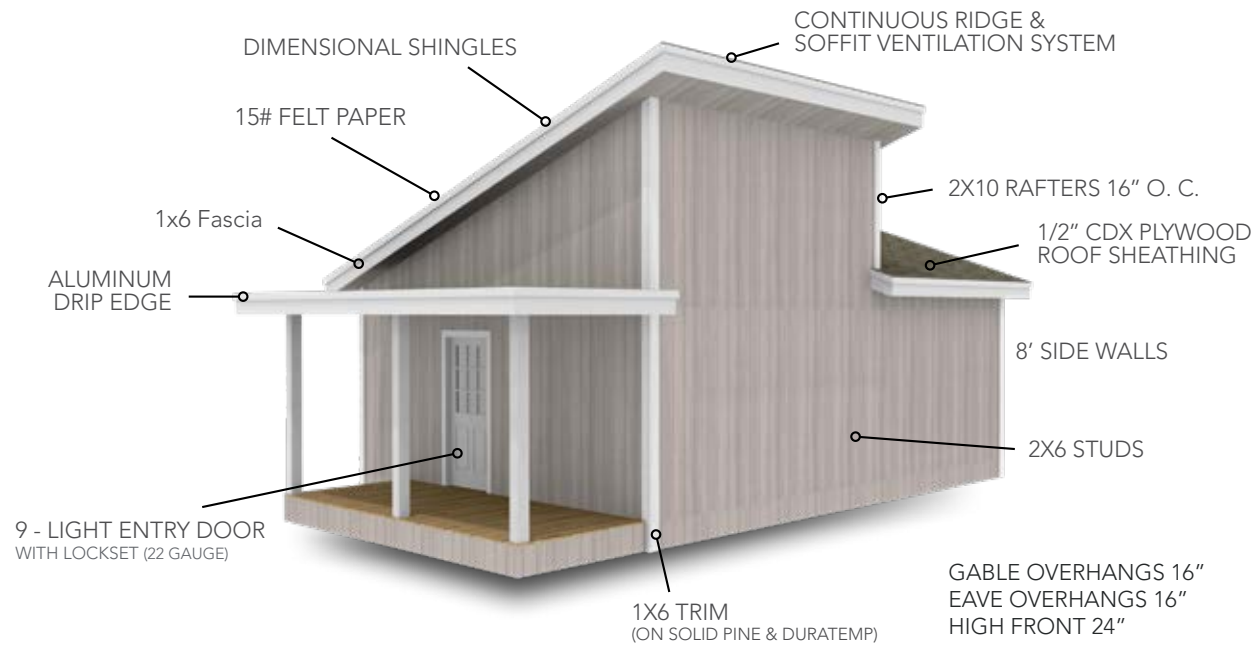

520 Sq. Ft.

## Floorplan

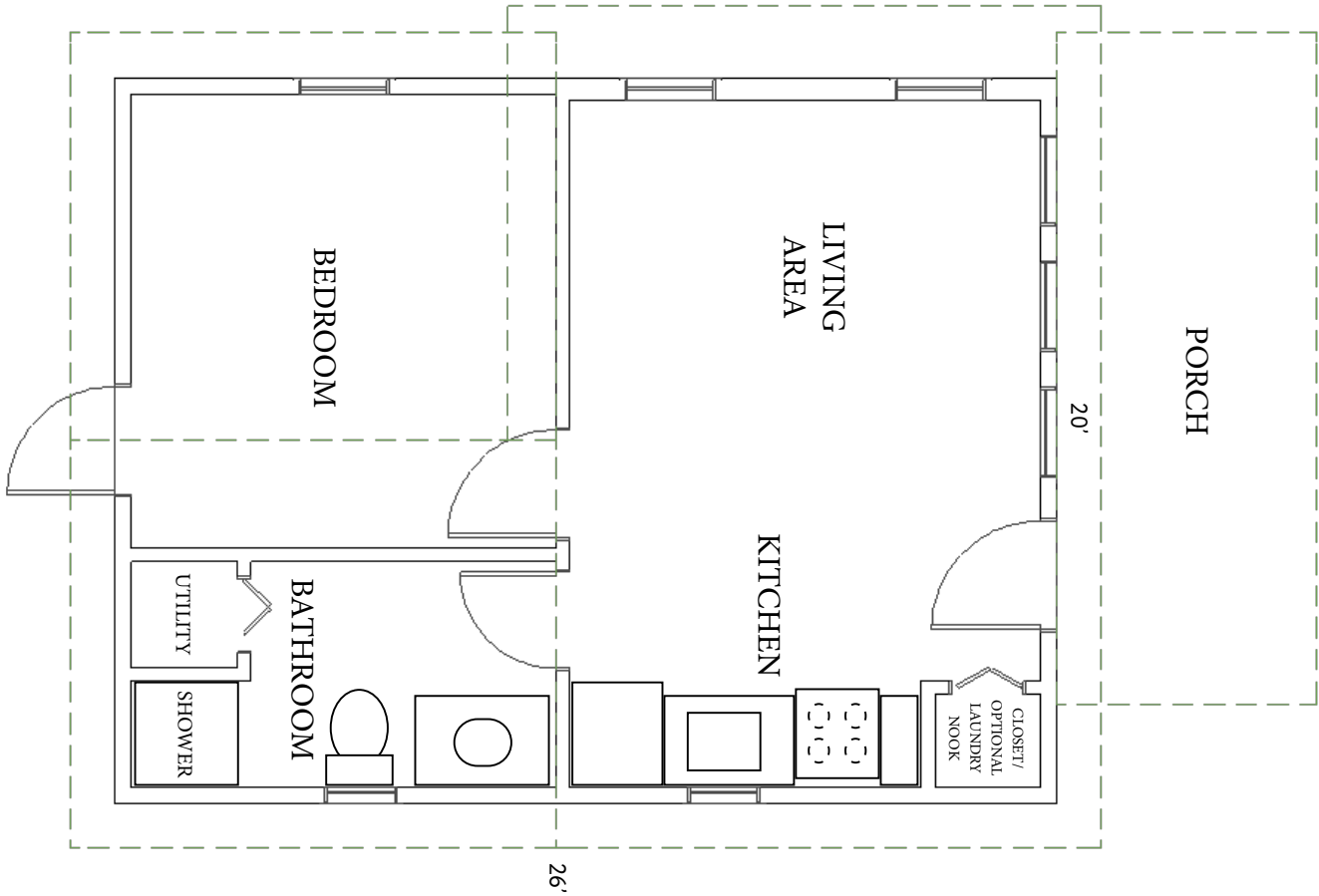





## Custom Homes & SPECIAL PROJECTS

At Weaver Barns we pride ourselves in our ability to build many different types of projects. Our clients come to us with a wide variety of unique requests and with our highly skilled team of craftsman we turn your ideas into reality. Talk to us about your custom dream project.





# Rocky Ridge | Homes

Size 20 x 32 910 Sq. Ft.



MAIN FLOOR

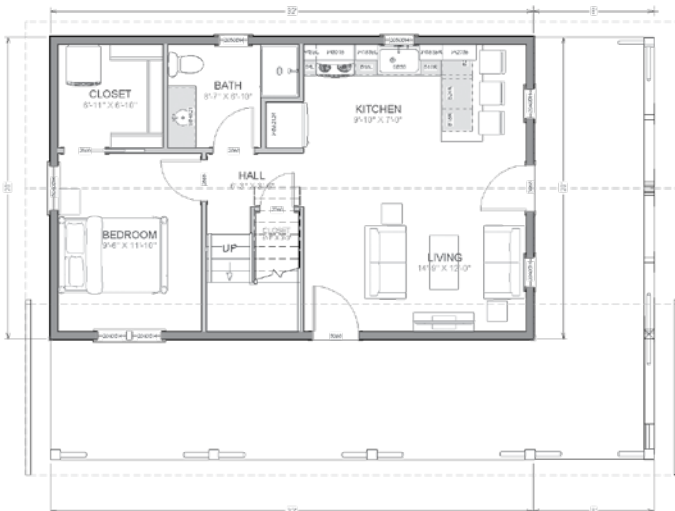

SECOND FLOOR

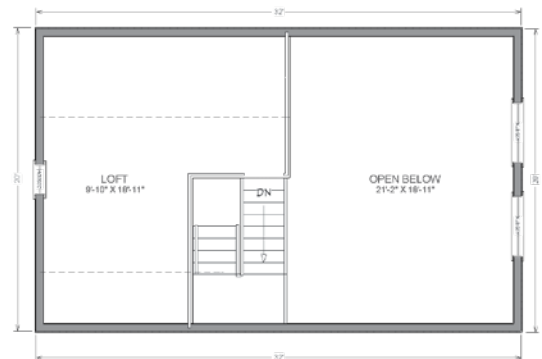



# Cedar Brooke I | Homes

Size 26 x 36 1453 Sq. Ft.

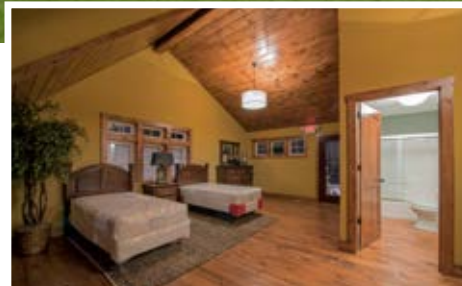

MAIN FLOOR



SECOND FLOOR





# Cedar Brooke II | Homes

Size 26 x 36 1512 Sq. Ft.

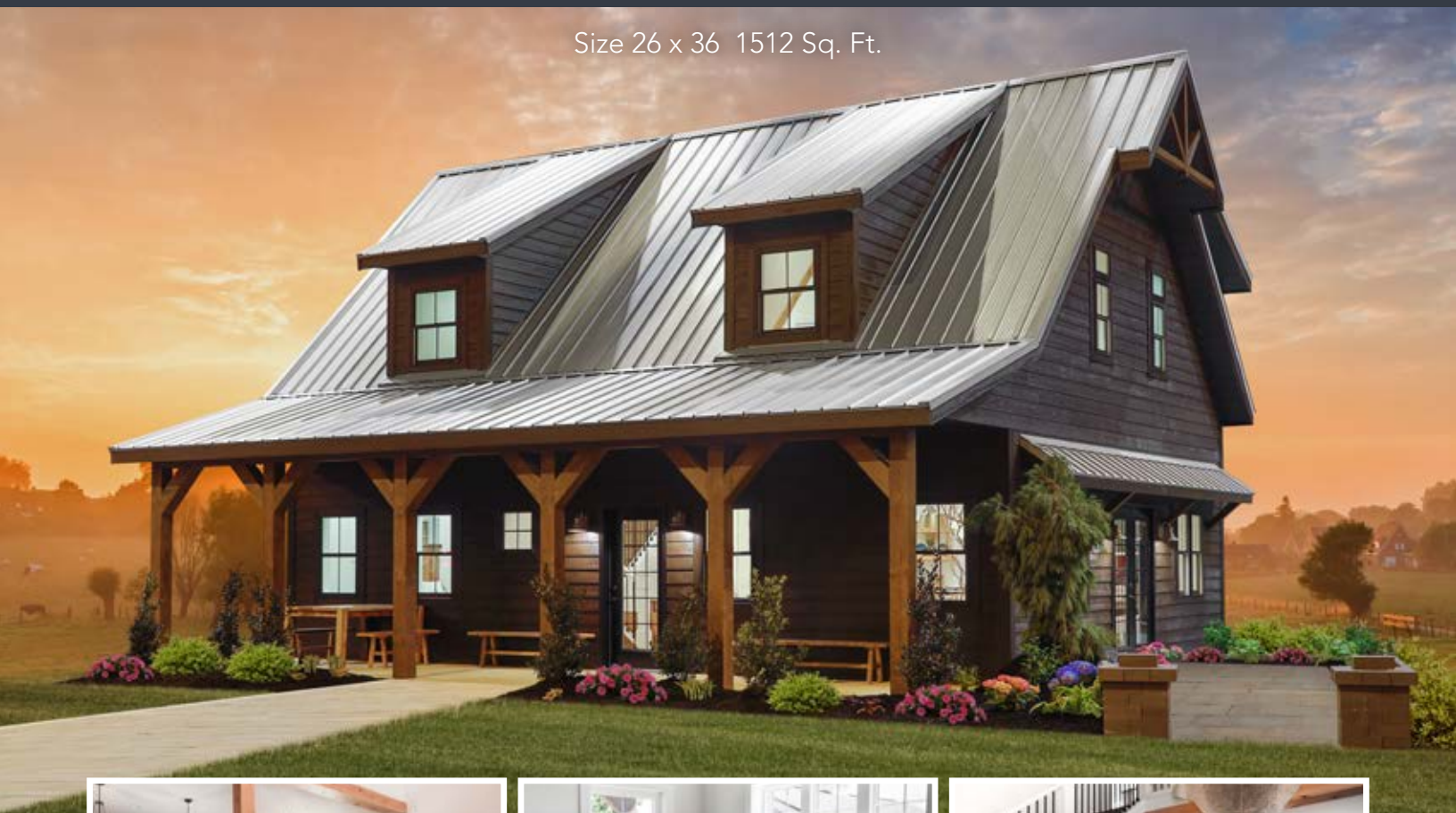

MAIN FLOOR



SECOND FLOOR





# Timber Lodge

Homes

Size 24 x 36 1260 Sq. Ft.



MAIN FLOOR

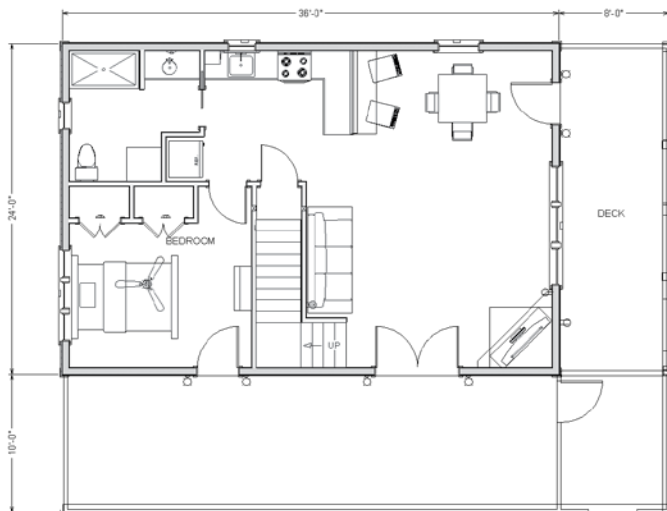

SECOND FLOOR

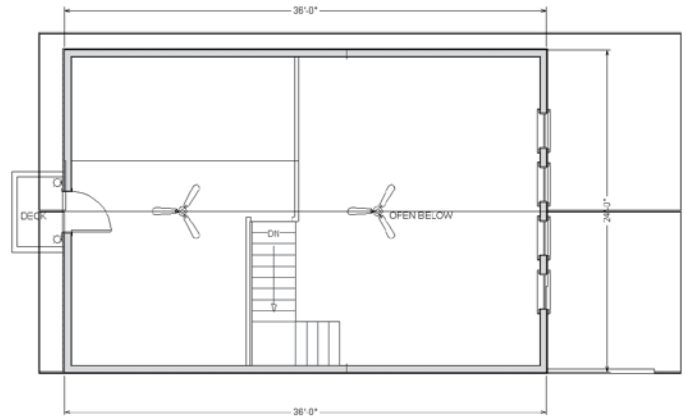



# Grand Lake | Homes

Size 32 x 40 2050 Sq. Ft.

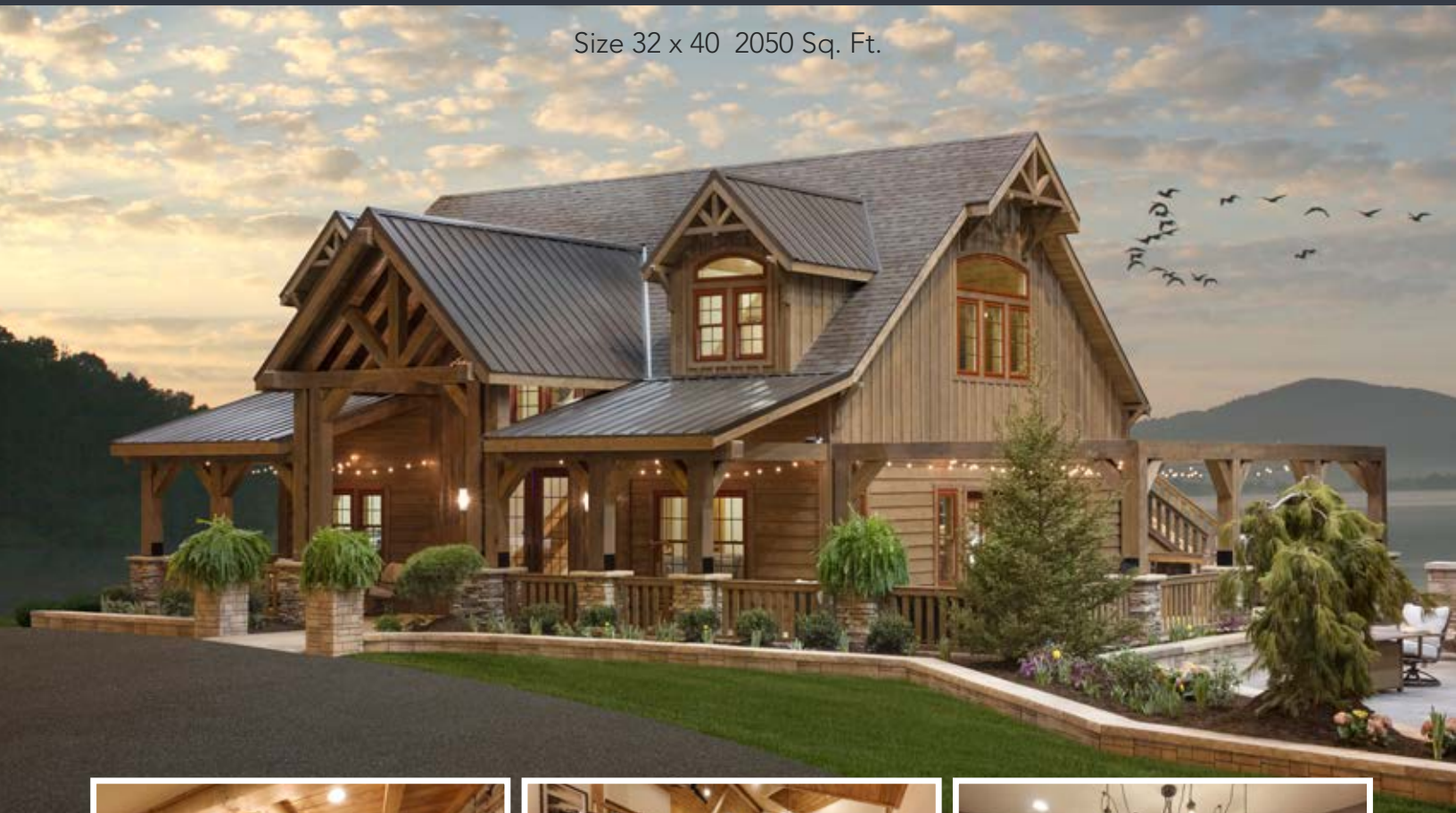

**MAIN FLOOR**

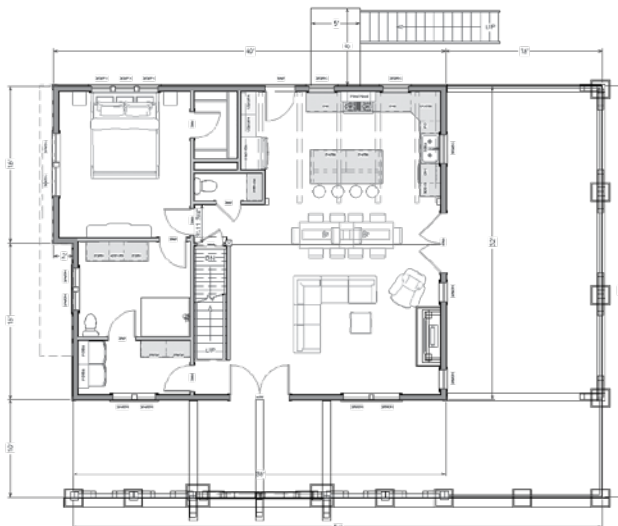

**SECOND FLOOR**

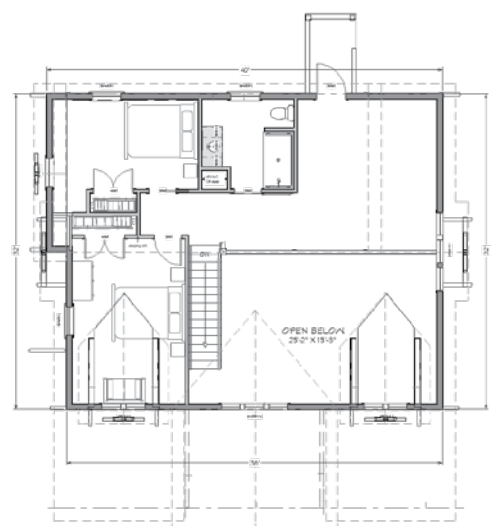



# DOORS

NOTE: Due to the effects of light, age, and printing processes, all color samples on these pages may vary in color or sheen from the actual materials.

## WOOD DOUBLE DOORS



#100  
sizes - 4' 5"  
6' 7"



#102-TW  
sizes - 4' 5"  
6' 7"



#101-SW  
sizes - 5' 6'



#103-AW  
sizes - 5' 6'



#200  
sizes - 4' 5"  
6' 7"



#202-TW  
sizes - 4' 5"  
6' 7"



#203-LW  
sizes - 5' 6'



#204-FW  
sizes - 5' 6'

## WOOD SINGLE DOORS



#100-SD  
sizes - 30" 36"



#102-SD  
sizes - 30" 36"



#101-SD  
sizes - 30" 36"



#103-SD  
sizes - 36"



#200-SD  
sizes - 30" 36"



#202-SD  
sizes - 30" 36"



#203-SD  
sizes - 30" 36"



#204-SD  
sizes - 36"

## WOOD TRIPLE DOORS



#100-TD  
sizes 7'6" - 9'

## WOOD SLIDING DOORS



10'x7'



10'x7' with transoms

# VINYL DOORS



#200-V  
sizes - 4' 5' 6' 7'



#202-V  
sizes - 4' 5' 6' 7'



#200-SDV  
sizes - 30" 36"



#202-SDV  
sizes - 30" 36"

Optional Colors



# STEEL ENTRY DOORS

Dead Bolt +\$ Painted Steel Door + \$ Stock Grid Colors White - Black - Clay - Bronze Special Grid Colors +\$



36" 6-Panel  
ECO (no-paint)  
24 - gauge  
22 - gauge



36" 9-Lite  
ECO (no-paint)  
24 - gauge  
22 - gauge



36" 15-Lite  
22 - gauge



36" 3-Lite  
22 - gauge



72" 6-Panel  
22 - gauge

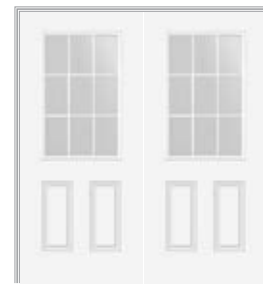

72" 9-Lite  
22 - gauge

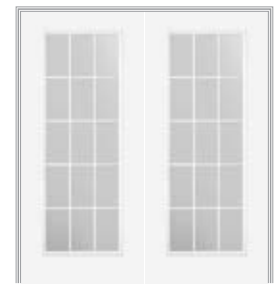

72" 15-Lite  
22 - gauge

Steel Door Colors \*Paint Is An Additional Charge

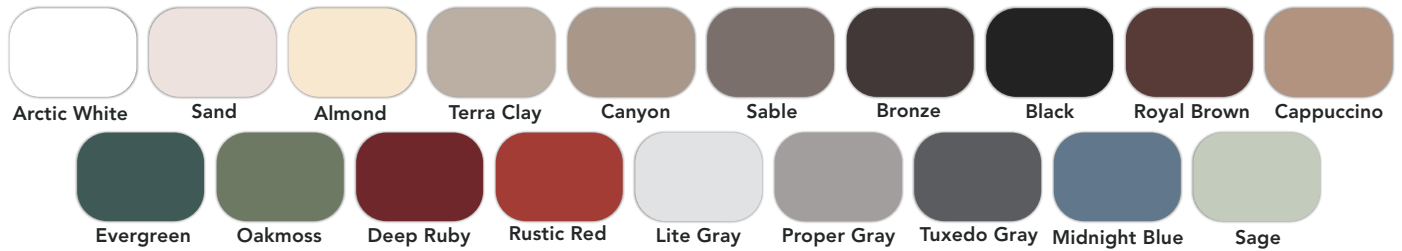

# OVERHEAD GARAGE DOORS

Garage Door Opener w/ One Remote +\$ Additional Remote +\$



Standard Door  
available insulated or uninsulated

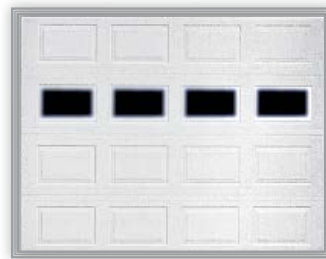

Standard Door with Optional Windows  
available insulated or uninsulated



Carriage House Door  
insulated



Glass Garage Door

Garage Door Colors



\*Only available on Standard Insulated and Carriage House Doors



# DOOR RAMPS



## Door Ramps

3' depth x width of door  
 4' depth x width of door  
 5' depth x width of door  
 ramps in excess of 5' (per sq. ft.)



## Diamond Plate Threshold

# DECORATIVES



Cedar Gable Vent



Peak Extension

# RAILING



1 x 4 Pine & Cedar Railing  
 \*available in vinyl



2 x 2 Pine & Treated Railing  
 \*available in vinyl



Wire Panel Railing  
 \*interior only



Rebar Railing  
 \*interior only

# STAIRS & LADDERS

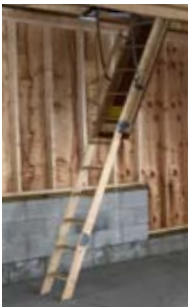

Attic Ladder



Straight Steps  
 (1x4 railing upgrade shown)  
 add risers plates



Steps With Landing & Handrail  
 (standard 2x2 railing shown)  
 add risers plates



Exterior Treated Steps  
 3 treads  
 steps & landing, cedar railing  
 additional tread  
 exterior treated landing



Sliding  
 Stair Ladder

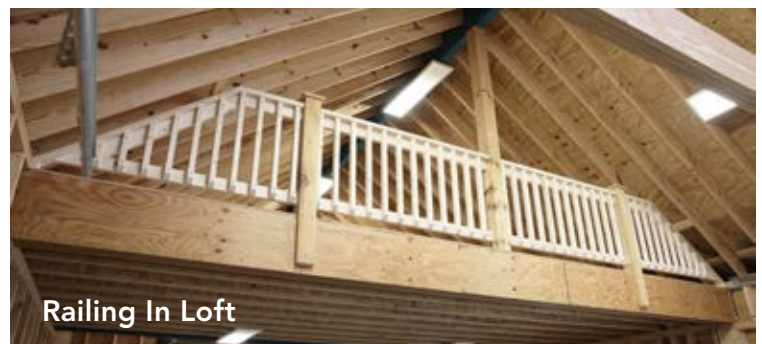

Railing In Loft

# WINDOWS

## ALUMINUM SINGLE-HUNG WINDOWS

Includes Screens & Grids - Choose: White/Brown/Black



AVAILABLE COLORS

## VINYL WINDOWS

Includes Screens & Grids - Color: White Upgrade: Almond, Black, Clay Muller Window

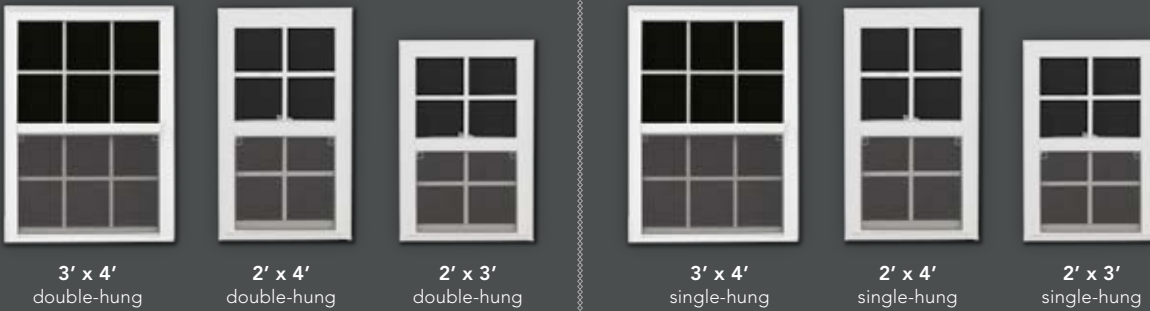

AVAILABLE COLORS

## ACCENT WINDOWS & SKYLIGHTS



2'x4' SKYLIGHT  
insulated

## WOOD PANEL SHUTTER STYLES



## WOOD/VINYL SHUTTERS & FLOWER BOXES

### WOOD



### VINYL





# CUPOLAS & WEATHER VANES



24"

32"

40"

## Traditional Cupola

Standard: solid cedar



24"

32"

40"

## Windowpane Cupola

Standard: solid cedar

\*frosted plexi-glass standard, clear available

## Roofing Colors



Galvalume



Bronze



Black

## CUPOLA OPTIONS

colored metal roof

110v light inside cupola

## Large Weather Vane

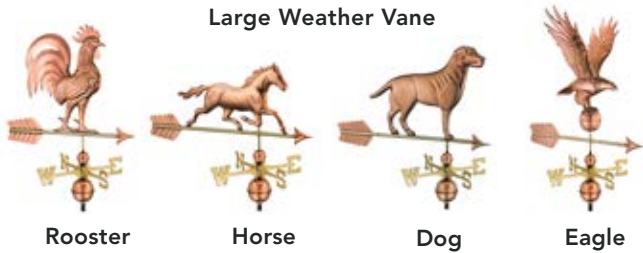

Rooster

Horse

Dog

Eagle

## Small Weather Vane

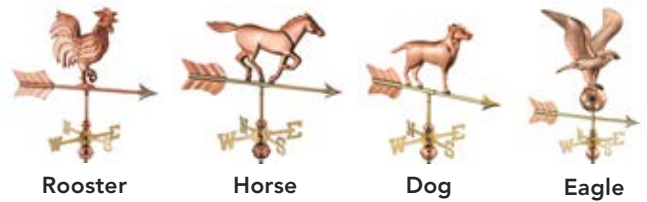

Rooster

Horse

Dog

Eagle

# SHELVES & WORKBENCHES

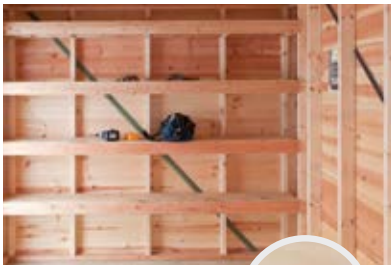

beveled

## 1' Depth

8' x 1' (2 x 4 joists)

10' x 1' (2 x 4 joists)

12' x 1' (2 x 4 joists with center post)

14' x 1' (2 x 4 joists with center post)

16' x 1' (2 x 4 joists with center post)

## 2' Depth

8' x 2' (2 x 4 joists)

10' x 2' (2 x 4 joists)

12' x 2' (2 x 4 joists with center post)

14' x 2' (2 x 4 joists with center post)

16' x 2' (2 x 4 joists with center post)



beveled

## Workbench (Freestanding)

8' x 2'

10' x 2'

12' x 2'

# STANDARD LOFTS & CUSTOM LOFTS

## Standard Sizes

8' x 4' (2 x 4 joists 16" o.c.)

10' x 4' (2 x 4 joists 16" o.c.)

12' x 4' (2 x 6 joists 16" o.c.)

14' x 4' (2 x 8 joists 16" o.c.)

16' x 4' (2 x 8 joists 16" o.c.)

## Custom Sizes

2 x 8 with 5/8" plywood (per sq. ft.)

2 x 10 with 3/4" plywood (per sq. ft.)

I-joists with 3/4" plywood (per sq. ft.)



# AWNINGS & ARBORS



Door Arbors



Open Rafter Awning



Door Awning



Cascade Awning



Shed Awning

## ROOF PITCH

**Sheds Steeper Roof Pitch** (up to 8/12 pitch)  
(per sq. ft. X 1 pitch increase)

**Sheds Steeper Roof Pitch** (9/12 to 12/12 pitch)  
(per sq. ft. X 1 pitch increase)

**Large Structures Steeper Roof Pitch** (up to 7/12 pitch)  
(per sq. ft. X 1 pitch increase)

*\*Ask your sales representative for 8/12 & higher pitch prices.*



## SIDEWALLS

### Sheds & Barns

1' increments per perimeter foot

### Pavilions

per post per foot up to 10'

### Cabins, Garages & Homes

1' increments per perimeter foot



## TRIM STYLES

## GABLE BRACKETS

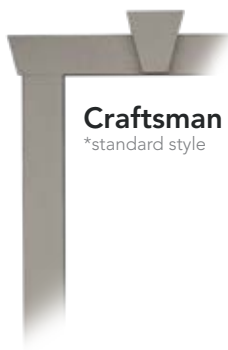

Timber Frame Bracket



# SHINGLES

## STANDARD DIMENSIONAL



## OPTIONAL DURATION



# OPTIONAL METAL ROOF



**NOTE:** Due to the effect of light, age, and printing processes, all color samples on these pages will vary in color or sheen from the actual materials.

**METAL ROOF** (per sq. ft.)  
 manchester & craftsman (per sq. ft.)  
 large structures (per sq. ft.)  
 dutch & cumberland (per sq. ft.)  
 legacy panel upgrade (per sq. ft.)  
 textured panel upgrade (per sq. ft.)

# VINYL SIDING COLORS

## STANDARD COLORS



## PREMIUM COLORS



Ask about our additional colors available for vinyl.

# PAINT COLORS



Silver Maple



Buckskin



Taupe



Driftwood



Dark Brown



Meadowview Ebony



Bear Beige



Navajo White



Espresso



Barn Red



Jamestown Red



Mountain Red



Jasper Gray



Clay



Timberbark



Truffle



Bronze



Pioneer



Dark Gray



Heritage Blue



Bora Bora



Deep Ocean



Midnight

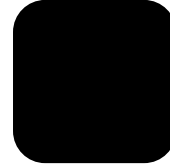

Black



Barn White



GP Gray



Steel Gray



Charcoal



Central States Charcoal



Mopboard Black



Avocado



Shale

**NOTE:** Due to the effect of light, age, and printing processes, all color samples on these pages will vary in color or sheen from the actual materials.

additional colors available

# STAIN COLORS

## PINE SIDING stain colors



Natural

Smoke

Pecan

Bark

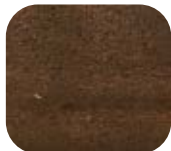

Chestnut Brown



Ebony



Dark Oak

## ENGINEERED SIDING stain colors

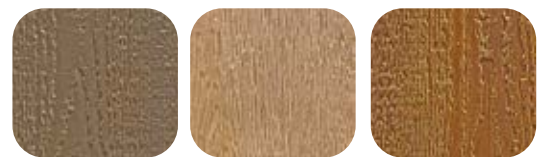

Smoke

Pecan

Bark



Chestnut Brown



Ebony





# Weaver Barns *ltd.*

"everyone needs a little structure in their life"

## 7-YEAR LIMITED WARRANTY

IF ANYTHING GOES WRONG OR IF WE DID SOMETHING WRONG WE WILL TAKE CARE OF IT

EXCLUSIONS: ACTS OF GOD, IMPROPER MAINTENANCE, USER DAMAGE, PAINT & STAIN, SEASONAL SETTLING, SHINGLE BLOW-OFFS DUE TO WIND

\*ON SIGNATURE MODELS



Like Us  
on Facebook



Follow Us  
on Pinterest



Find Us  
on Houzz



Follow Us  
on Instagram